

3

Technical features
Aspectos técnicos

2

Projects
Proyectos

1

The brand
La marca

Introduction
Introducción p. 03

History
Historia p. 12

International
Internacional p. 20

Manufacturing process
Proceso de fabricación p. 22

Local development
Desarrollo local p. 38

Education
Educación p. 38

Awards
Premios p. 39



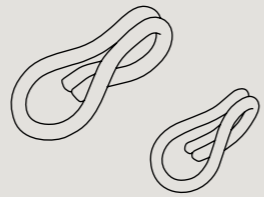

3

Technical features

Aspectos técnicos

2

Projects

Proyectos

We are pleased to present Kriska and its little sister Snina. They are our essence and the spirit of a road we began to travel many years ago. One by one, they create infinite chains that offer unlimited possibilities for those who dare to play with them.

Manufactured in aluminium, they are tiny, although they can get very large, as well as warm, elegant, and formal. And when they play around with colour, they can become an explosion of fun. They're special because they can create and transform spaces with their presence alone. They're not merely what you see; they can actually become anything you imagine.

Os presentamos a Kriska y a su hermana pequeña Snina. Ellas son nuestra esencia y el espíritu de un camino que empezamos a recorrer hace años. Una a una, crean cadenas infinitas que ofrecen posibilidades ilimitadas a quienes se atreven a jugar con ellas.

Fabricadas en aluminio, son menudas, aunque pueden llegar a ser muy grandes, además de cálidas, elegantes y formales. Y si se les suben los colores, pueden convertirse en toda una explosión de diversión.

Son especiales porque pueden generar y transformar espacios con su sola presencia. No son simplemente lo que ves, ellas pueden ser todo lo que tú imaginas.

3

Technical features
Aspectos técnicos

2

Projects
Proyectos

Kriskadecor

4

**THEY ARE
UNIQUE &
SPECIAL JUST
BECAUSE THEY
ARE THE WAY
THEY ARE...**

5

The brand La marca

**SON
ÚNICAS Y
ESPECIALES,
SOLO POR
SER COMO
SON...**



3

Technical features
Aspectos técnicos

2

Projects
Proyectos

Modular and versatile Modulares y versátiles

Kriska and Snina are designed to make chains as long as needed, becoming the true stars in a wide variety of places and environments. They can be hung, combined, fixed at one or both ends, joined together, made into shapes... An infinite list of possibilities for unique projects.

Kriska y Snina están diseñadas para formar cadenas tan largas como sea necesario, convirtiéndose en las verdaderas protagonistas de lugares y ambientes muy distintos. Se pueden colgar, combinar, fijar por uno o por ambos extremos, unir entre ellas, crear formas... Una lista infinita de posibilidades para proyectos únicos.

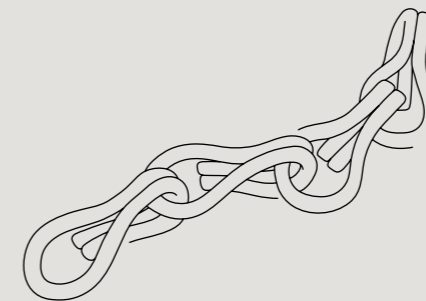

3

Technical features
Aspectos técnicos

2

Projects
Proyectos



3

Technical features
Aspectos técnicos

2

Projects
Proyectos

Kriskadecor

10

Do you have an idea?
Kriska can be the
star of your creation,
your project.
Play with it - it's
daring, and it has
no limits. Think,
imagine... What
would you do
with Kriska?

11

The brand La marca

¿Tienes una idea?
Kriska puede ser la
protagonista
de tu creación,
de tu proyecto.
Juega con ella,
es atrevida y
no tiene límites.
Piensa, imagina,
¿qué harías con
Kriska?



Centenarian chain links Eslabones centenarios

The design of the first chain link has almost 100 years of history, and thanks to constant R&D efforts, it has evolved until becoming what it is today, Kriska, born in 1972.

Snina arrived shortly afterwards, a version of the same link for more defined, subtle applications.

El diseño del primer eslabón cuenta con casi 100 años de historia y gracias a un esfuerzo continuo en I+D+i, ha ido evolucionando hasta convertirse en lo que es hoy, Kriska, nacida en 1972.

Poco tiempo después llega Snina, una versión del mismo eslabón para aplicaciones más definidas y sutiles.

3

Technical features
Aspectos técnicos

2

Projects
Proyectos

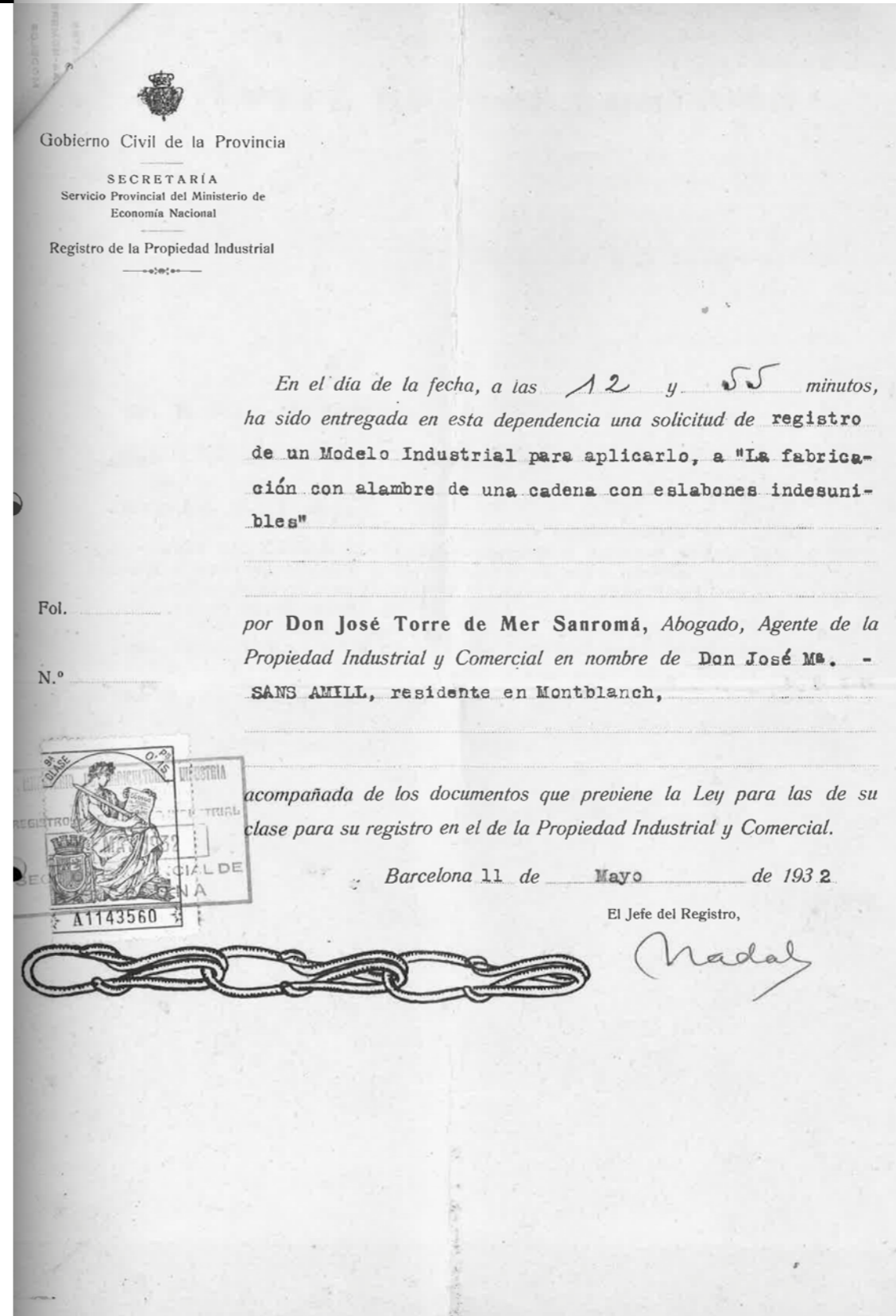

1926 The origin of everything El origen de todo

Our story begins back in 1926, in Montblanc (Catalonia, Spain). The first chain link was created by Josep Maria Sans Amill, our founder, who developed the first machine and managed to have chain curtains spread all over the Mediterranean. Decades later, after painstakingly researching raw materials, his son, Josep Maria Sans Folch, designed the new chain links. He improved the technique for working with anodised aluminium, which enabled him to add a wide range of colours. His wife, Josefina Esplugas, contributed actively to the company's expansion.

Nuestra historia empieza en 1926, en Montblanc (Cataluña, España). El primer eslabón nace de la mano de Josep Maria Sans Amill, nuestro fundador, quien desarrolló la primera máquina y consiguió que las cortinas de cadena se extendieran por todo el Mediterráneo.

Décadas más tarde, su hijo, Josep Maria Sans Folch, tras una ardua investigación de la materia prima, diseñó los nuevos eslabones y mejoró la técnica para trabajar con aluminio anodizado, lo que permitió incorporar una amplia gama de colores.

Su esposa, Josefina Esplugas, contribuyó activamente a la expansión de la empresa.

3

Technical features
Aspectos técnicos

2

Projects
Proyectos





3

Technical features
Aspectos técnicos

2

Projects
Proyectos

17

The brand La marca

2003 The birth of Kriskadecor El nacimiento de Kriskadecor

With the turn of the century, Kriska and Snina left private homes and shops and began to shine in grand hotels and buildings all over the world. What a long road they've travelled, and how many new possibilities have opened up!
Con el cambio de siglo, Kriska y Snina abandonaron las casas particulares y los comercios y empezaron a lucirse en grandes hoteles y edificios de todo el mundo. ¡Qué largo camino habían recorrido y cuántas posibilidades nuevas se abrieron!



Now El ahora

The company is currently led by the third generation of the Sans family, but Josep Maria and Maties always keep in mind what their grandfather used to say: 'There's nothing that can't be done; you just have to find the way'.

That's how it is at Kriskadecor. We are excited to think that, from our chain links, ambitious projects are born in collaboration with the most creative professionals.

Actualmente, la compañía está liderada por la tercera generación de la familia Sans, pero Josep Maria y Maties tienen muy presente lo que su abuelo solía decir: "No hay nada que no se pueda hacer, solo hay que encontrar la manera". Y es así como seguimos en Kriskadecor, entusiasmados con la idea de que, a partir de nuestros eslabones, nazcan tantísimos proyectos en colaboración con los profesionales más creativos.

3

Technical features
Aspectos técnicos

2

Projects
Proyectos

'There's nothing that
can't be done;
you just have to find
the way'.

"No hay nada que no
se pueda hacer, solo
hay que encontrar
la manera".

Josep Maria Sans, Founder Fundador



3

Technical features
Aspectos técnicos

2

Projects
Proyectos



International
Internacional

Kriskadecor is a global brand that knows no borders. We export 80% of our production, having carried out projects in more than 90 countries, which has allowed us to get to know and adapt to the most diverse environments and cultures. From our headquarters in Montblanc (Spain) and Miami (United States), we work with a broad network of agents and distributors all over the world.

We love partnering with architecture and interior design firms, both internationally renowned and up-and-coming professionals.

And best of all: we love to be part of their projects and help bring them to fruition.

Kriskadecor es una marca global que no entiende de fronteras. Exportamos un 80% de nuestra producción, habiendo realizado proyectos en más de 90 países, hecho que nos ha permitido conocer y adaptarnos a escenarios y culturas de lo más diverso.

Trabajamos desde nuestras sedes en Montblanc (España) y Miami (Estados Unidos) con una amplia red de agentes y distribuidores en todo el mundo.

Nos apasiona colaborar con despachos de arquitectura e interiorismo, tanto de reconocida fama mundial como profesionales noveles.

Y lo mejor de todo: nos encanta formar parte de sus proyectos y hacerlos realidad.



Industrial craftsmanship Artesanía industrial

We oversee the manufacturing process from beginning to end, from the creation of the chain links to the structure of the project, making sure that the end result is an exclusive piece.

To achieve this, we have developed a unique manufacturing process which has been fine-tuned over the years by relying on an essential cornerstone: the human component.

Kriska and Snina spring from a perfect balance between an industrial process and the oversight of our technicians, whose expert hands check each project in detail.

Controlamos el proceso de fabricación de principio a fin, desde la creación de los eslabones a la estructura del proyecto, asegurándonos de que el resultado final sea una pieza exclusiva. Para conseguirlo hemos desarrollado un proceso productivo único, perfeccionado a lo largo de los años con un pilar fundamental: el componente humano.

Kriska y Snina nacen fruto de un perfecto equilibrio entre un proceso industrial y la supervisión de nuestros técnicos que, con sus manos expertas, revisan cada proyecto al detalle.

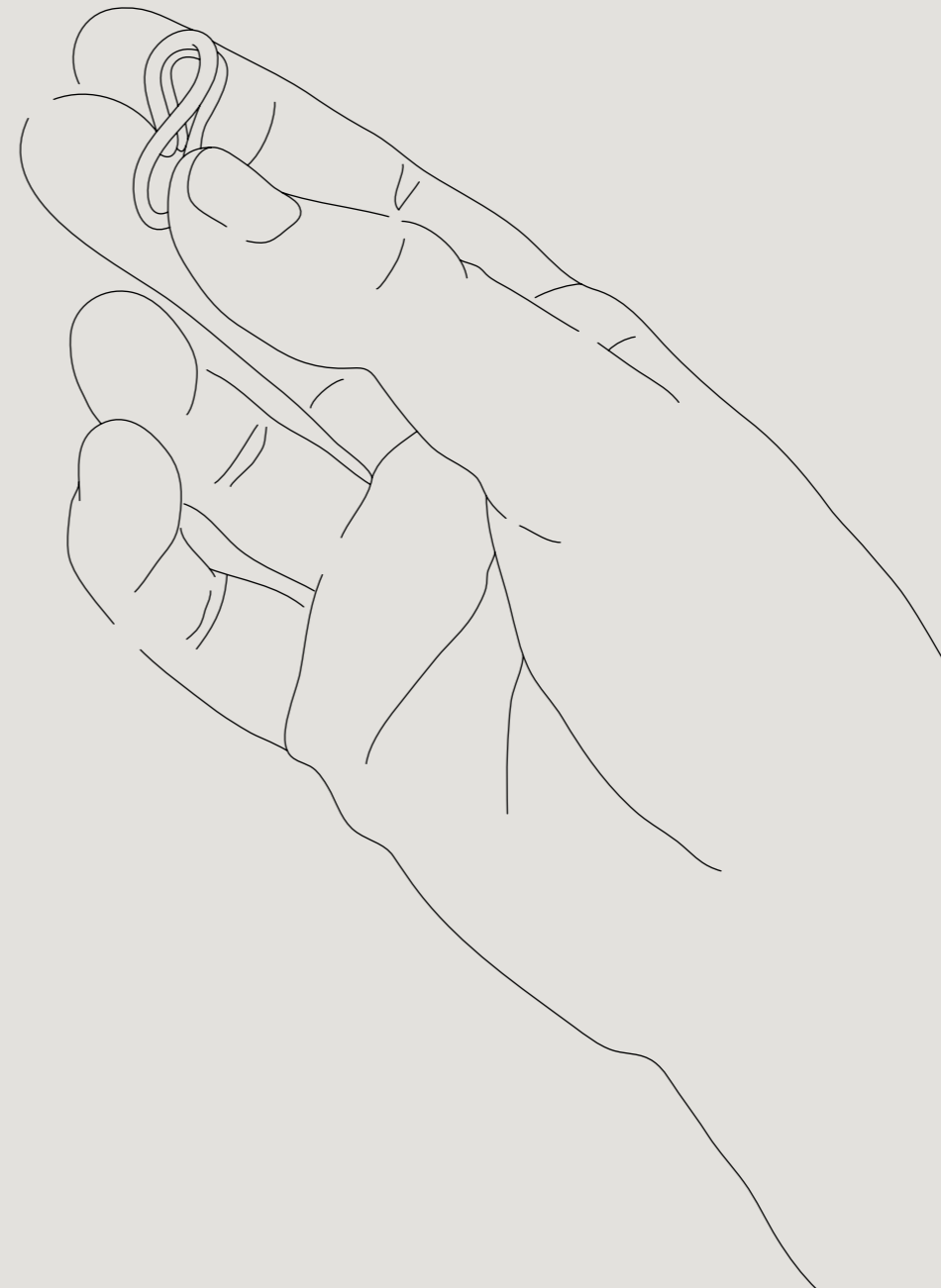

Our technical office Nuestra oficina técnica

Going above and beyond what our clients expect is in our DNA. This is why our Design and Innovation team is vitally important for each project's development.

We work with our clients throughout the process to ensure that their idea gets the best outcome through technical and design advice, assessment of special structures, cost calculations and drawing up blueprints and assembly instructions.

Ir más allá de lo que nuestro cliente espera está en nuestro ADN. Por ello, el equipo de Diseño e Innovación es de vital importancia en el desarrollo de cada proyecto.

Acompañamos a nuestros clientes a lo largo de todo el proceso para conseguir que su idea se materialice a la perfección mediante asesoramiento técnico y de diseño, valoración de estructuras especiales, cálculo de costes y realización de planos e instrucciones de montaje.

3

Technical features
Aspectos técnicos

2

Projects
Proyectos



3

Technical features
Aspectos técnicos

2

Projects
Proyectos

Our raw material Nuestra materia prima

The quality and reliability of our product are due to our vast cumulative experience working with aluminium. Kriska and Snina are manufactured with 99.99% top quality aluminium, a highly sustainable building material.

La calidad y fiabilidad de nuestro producto se debe a la gran experiencia acumulada trabajando con el aluminio.

Kriska y Snina se fabrican con aluminio 99.99% de calidad superior, un material constructivo altamente sostenible.

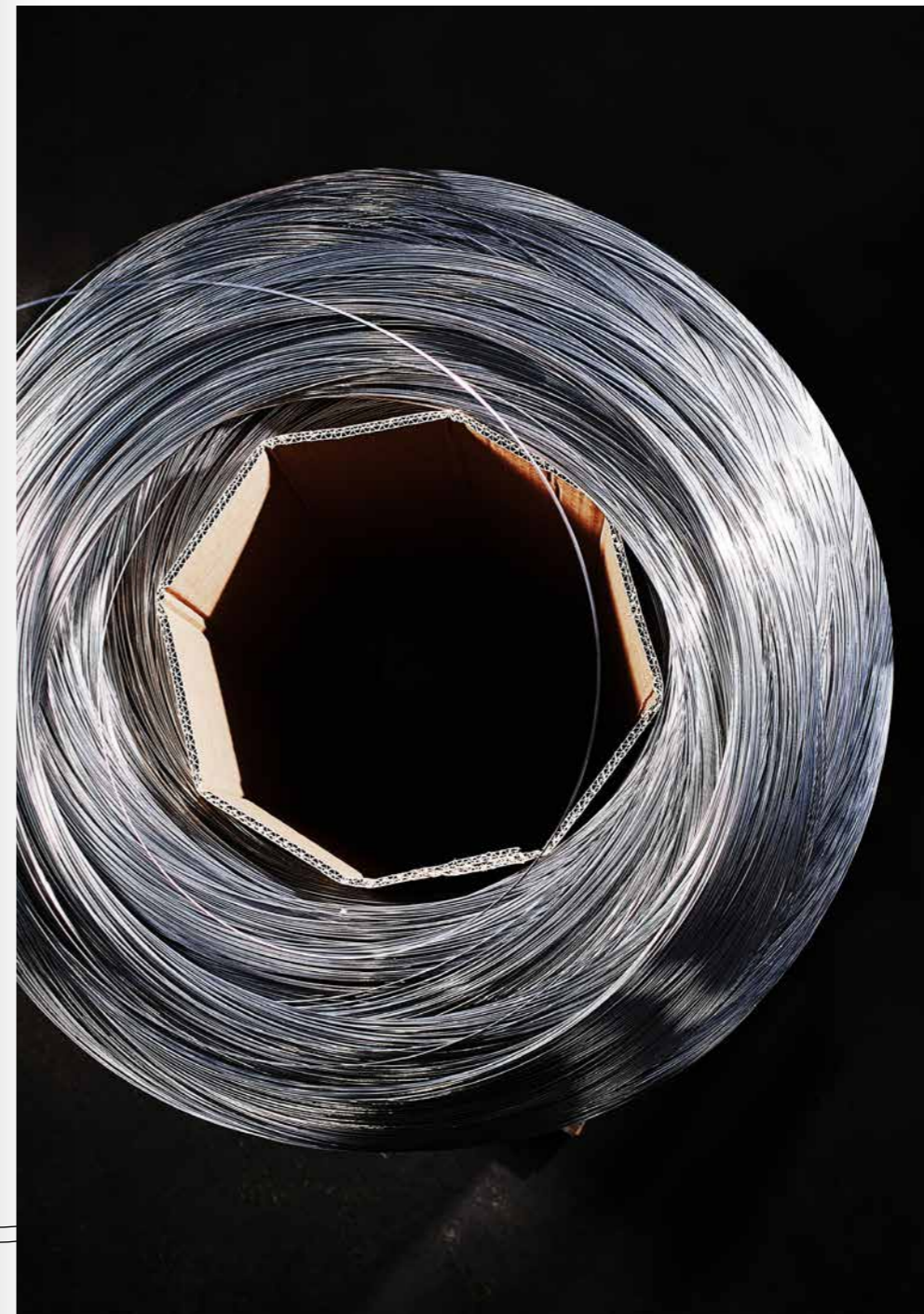



3

Technical features
Aspectos técnicos

2

Projects
Proyectos

29

The brand La marca

The creation of our chain links

La creación de nuestros
eslabones

Kriska and Snina are born from an aluminium thread that we transform into small chain links with in-house technology. Once joined, they create long chains to give life to surprising projects.

Kriska y Snina nacen a partir de un hilo de aluminio que transformamos en pequeños eslabones con tecnología propia y que una vez unidos, crean largas cadenas para dar vida a proyectos sorprendentes.



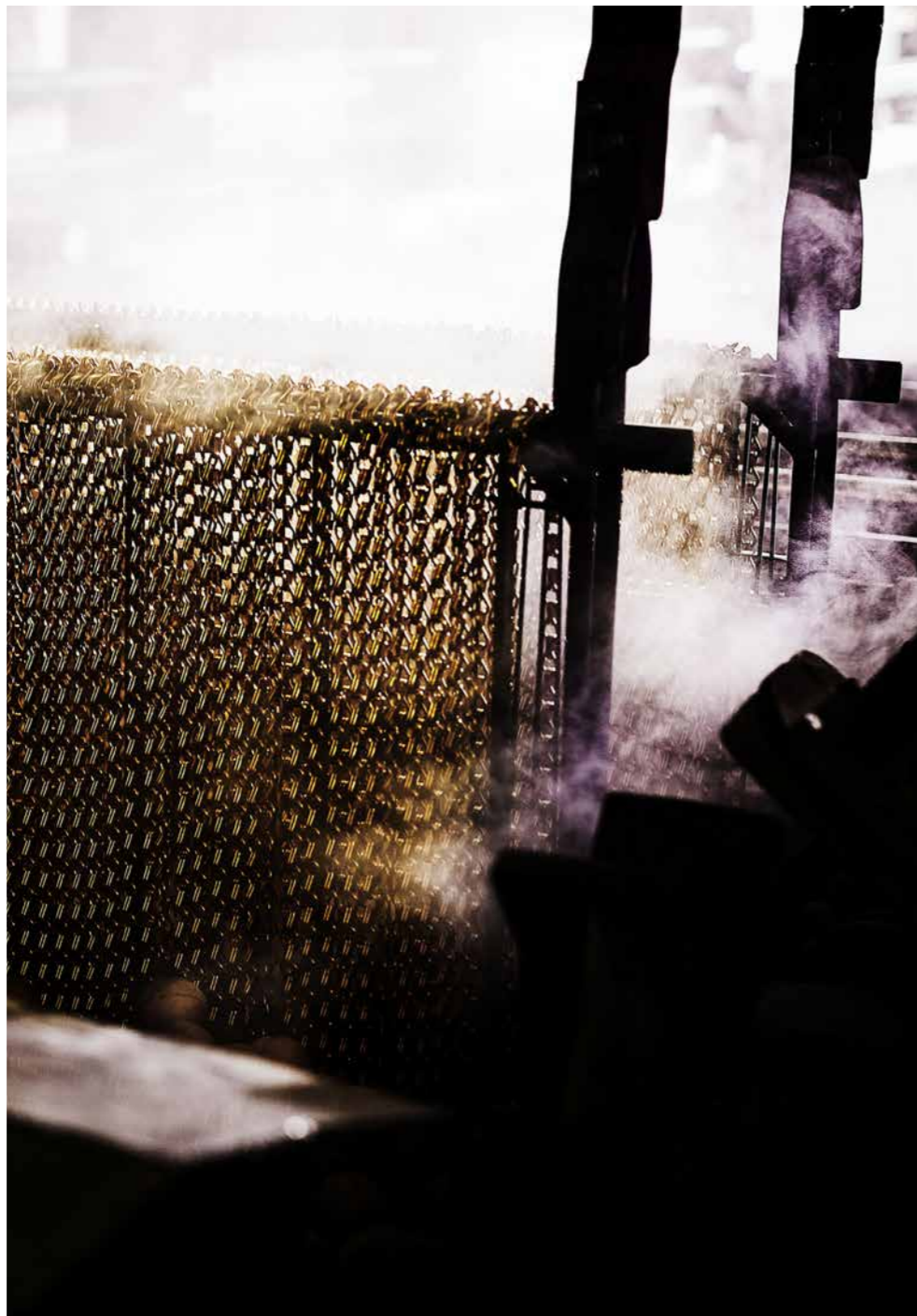

3

Technical features
Aspectos técnicos

2

Projects
Proyectos



Anodising and colouring
Anodizado y coloración

The quality of our chains comes from an internal anodisation process which brings them colour, stability and hardness.

This internal process enables us to achieve an extensive palette of our own and personalised colours with brilliant and satin finishes.

La calidad de nuestras cadenas se materializa gracias a un proceso interno de anodizado que les aporta color, estabilidad y dureza.

Este proceso interno nos permite obtener una gran paleta de colores propios y personalizados con acabados brillantes y satinados.



3

Technical features
Aspectos técnicos

2

Projects
Proyectos

Kriskadecor

32

Weaving chains Tejiendo cadenas

Inspired by the ancestral art of weaving, we combine large spools of colours as if they were thread bobbins to create high-definition images or patterns with spectacular finishes.

Inspirados en la ancestral técnica de tejer, combinamos grandes carretes de colores como si fuesen bobinas de hilo, para crear imágenes o patrones en alta definición con espectaculares acabados.

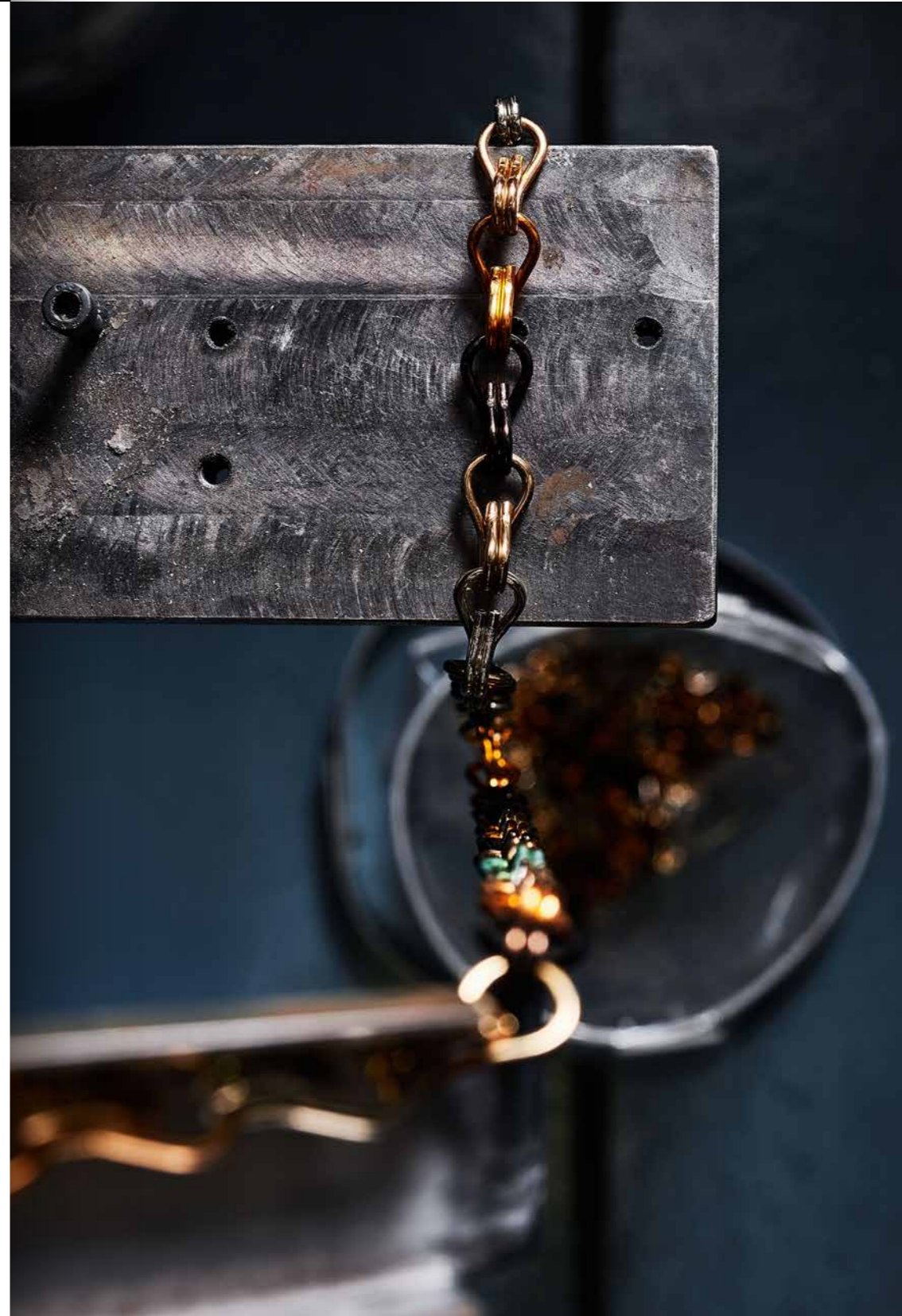
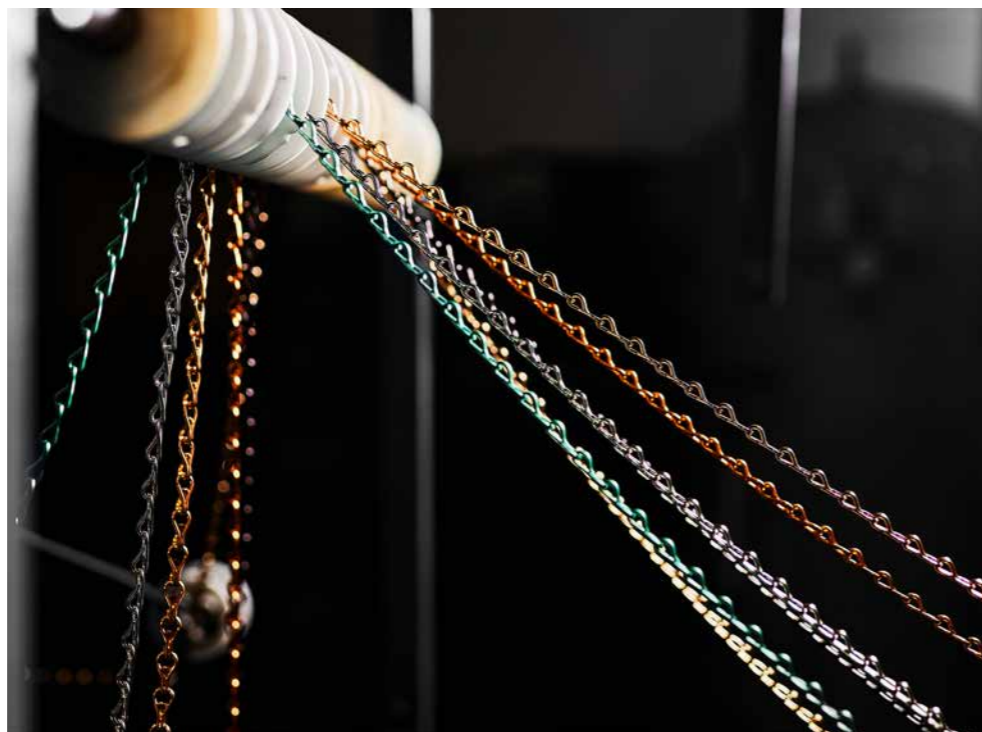

3

Technical features
Aspectos técnicos

2

Projects
Proyectos

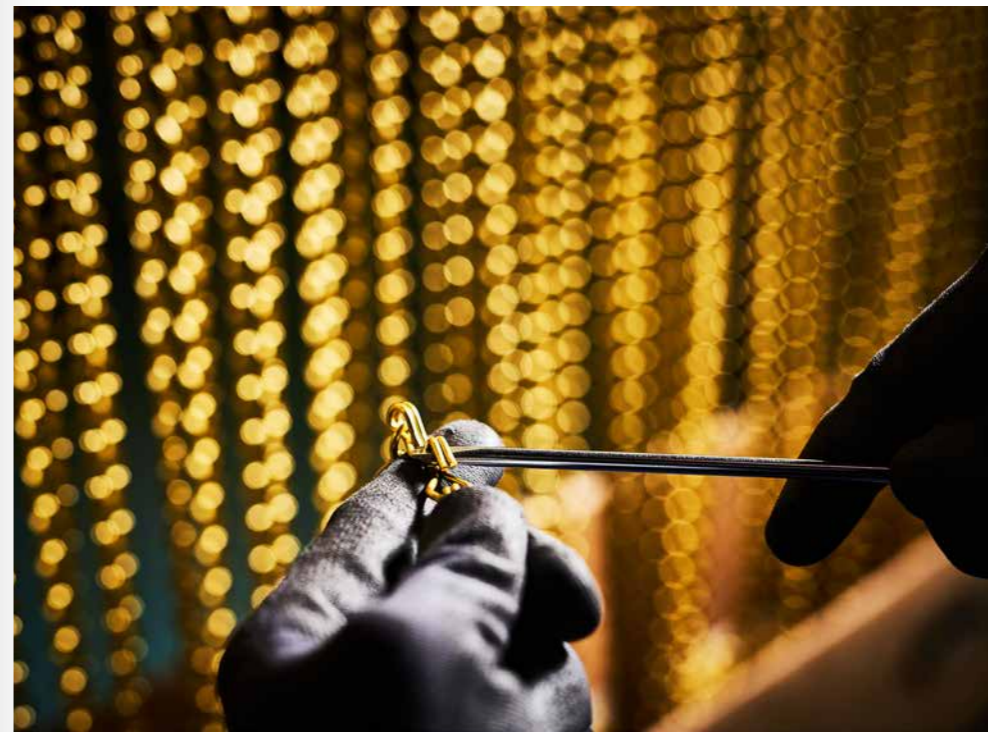
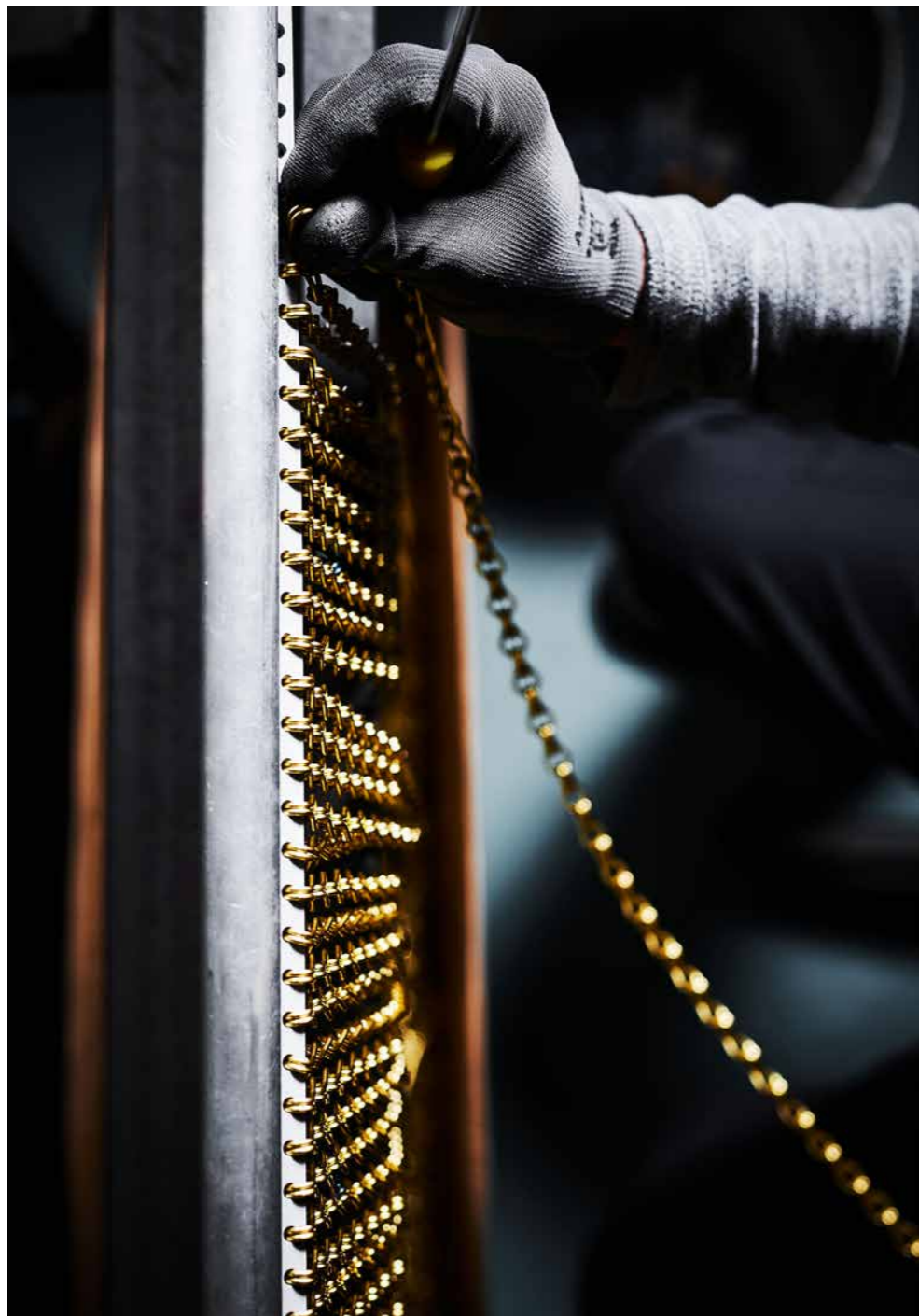



3

Technical features
Aspectos técnicos

2

Projects
Proyectos

37

The brand La marca

Quality is in the details La calidad de los detalles

Our internal controls ensure that the project's end result will be of the highest quality. Each creation is hand-checked to make sure that the installation is performed correctly. Nuestros controles internos garantizan que el resultado final del proyecto tendrá una calidad óptima. Cada creación se revisa manualmente para garantizar que la instalación se lleve a cabo correctamente.



Local development Desarrollo local

At Kriskadecor, we contribute actively to our region's social and cultural development. We are an important part of the local business community, and we participate in charitable initiatives, sponsor sports competitions and clubs, and promote festivals such as the Mediaeval Week in Montblanc.

En Kriskadecor contribuimos activamente al desarrollo social y cultural de la zona. Somos una pieza importante del tejido empresarial local, colaborando con iniciativas solidarias, patrocinando entidades deportivas y promoviendo festividades como la Semana Medieval de Montblanc.

Education Educación

We believe that spending time on training talented youths is one of the most important human capital investments our company can undertake. Therefore we work with educational organisations to offer internships to students in vocational and university degree programmes. Creemos que dedicar tiempo a la formación de talento joven es una de las inversiones en capital humano más importantes que nuestra empresa puede llevar a cabo. Por este motivo, colaboramos con entidades educativas, ofreciendo programas de prácticas a estudiantes de ciclos formativos y grados universitarios.

3

Technical features Aspectos técnicos

2

Projects Proyectos

Awards Premios

Owing to our resolve to offer innovative, new products, we work with renowned international designers.

Thanks to these partnerships, we have been distinguished with many awards:

Debido a nuestro empeño en ofrecer nuevos e innovadores productos, trabajamos con diseñadores internacionales de reconocida trayectoria.

Fruto de estas colaboraciones, nos han concedido diversos premios:



Bronze Delta
ADI Awards 2020

Delta Bronze award in 2020
For the Gradient Collection in the category of 'Interior Equipment'.

[Delta de Bronce 2020](#)

Para Gradient Collection en la categoría de "Equipamiento interior".



BEST OF YEAR
WINNER 2019
INTERIOR
DESIGN

Best of Year 2019
For the Gradient Collection in the category of 'Architectural Products'

[Best of Year 2019](#)
Para Gradient Collection en la categoría de "Architectural products"



EXHIBITOR
2020 HONORABLE
MENTION

Honorable Mention Small Stand at Euroshop 2020

EXHIBITOR Magazine's EuroShop Awards.

[Honorable Mention Small Stand at Euroshop 2020](#)

En los EXHIBITOR Magazine's EuroShop Awards.



BEST OF YEAR
WINNER 2018
INTERIOR
DESIGN

Best of Year 2018
For the Aura Collection in the category of 'Architectural Lighting'

[Best of Year 2018](#)
Para Aura Collection en la categoría de "Architectural Lighting".

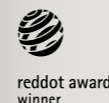

reddot award 2019
winner

Red Dot Award: Product Design 2019

For the Aura Collection.

[Red Dot Award: Product Design 2019](#)

Para Aura Collection.



INTERIOR
DESIGN
HiP
at NeoCon
WINNER 2016

HiP 2016 - Architectural & Building Products: Partitions

For the Rainy Ceiling system.

[HiP 2016 - Architectural & Building Products: Partitions](#)

Para el sistema Rainy Ceiling.



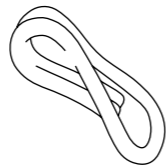

3

Technical features
Aspectos técnicos

2

Projects
Proyectos

Space dividers
Separadores de espacio p. 42

Wallcoverings
Paredes p. 52

Ceiling features
Techos p. 62

Lighting elements
Elementos de iluminación p. 76

Cladding
Revestimientos de interior
y exterior p. 84

Other uses p. 94
Otros usos

Products p. 108
Productos

Patterns p. 116
Estampados

Straight · Curved · Undulated · Fixed · Movable
 BCN Tensed System · BCN Framed System
 Shaped Frame

We create completely personalised space dividers with geometric and organic shapes. We can even include personalised images and designs to create astonishing atmospheres.

Space dividers

Separadores de espacio

Rectos · Curvos · Ondulados · Fijos · Móviles
 BCN Tensed System · BCN Framed System
 Shaped Frame

Creamos separadores de espacio totalmente personalizados con formas geométricas y orgánicas que, además, pueden incluir imágenes y diseños personalizados para crear atmósferas sorprendentes.

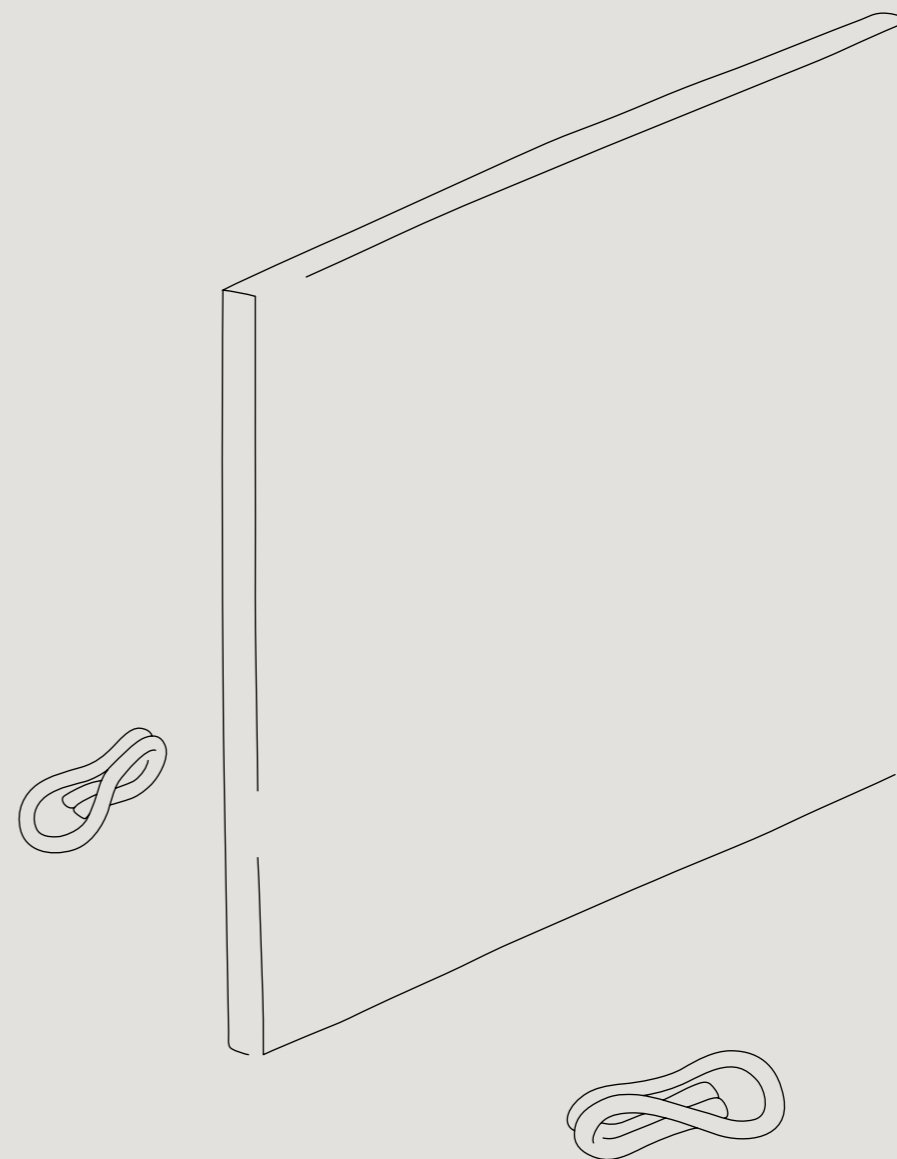

MIQ

Project type Tipo de proyecto

Offices Oficinas

Design solution Solución de diseño

— Straight Recta

Link Eslabón

 Kriska

Design Diseño

Sydney Architects

Design Republic

Emma Louise Ingham Design

Location Localización

New York City, NY, USA



PHOTOS BY JON NISSENBAUM

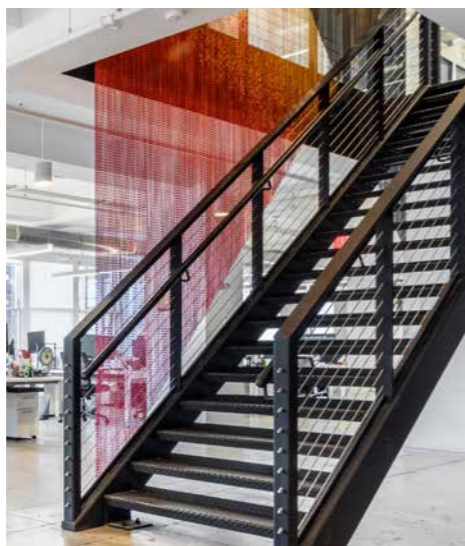

3

Technical features Aspectos técnicos



PHOTO BY DENIS VASILIEV

MANDARIN. NOODLES AND DUCKS

Project type Tipo de proyecto

Hotels and restaurants Hoteles y restaurantes

Design solution Solución de diseño

 Curved Curva

Link Eslabón

 Snina

Design Diseño

Sundukovy Sisters

Location Localización

Moscow, Russia

3

Technical features
Aspectos técnicos

CITY OF MANCHESTER STADIUM

Project type Tipo de proyecto

Leisure Ocio

Design solution Solución de diseño

Curved Curva

Link Eslabón

Kriska

Design Diseño

20|20 Design

Location Localización

Manchester, UK





PHOTO BY DS.ARQUITECTES

LE MÉRIDIEN RA BEACH HOTEL & SPA

Project type Tipo de proyecto

Hotels and restaurants Hoteles y restaurantes

Design solution Solución de diseño

 Curved Curva

Link Eslabón

 Kriska

Design Diseño

Ds. Arquitectes: Sandra Dachs + Núria Selva

Location Localización

Tarragona, Spain

3

Technical features Aspectos técnicos

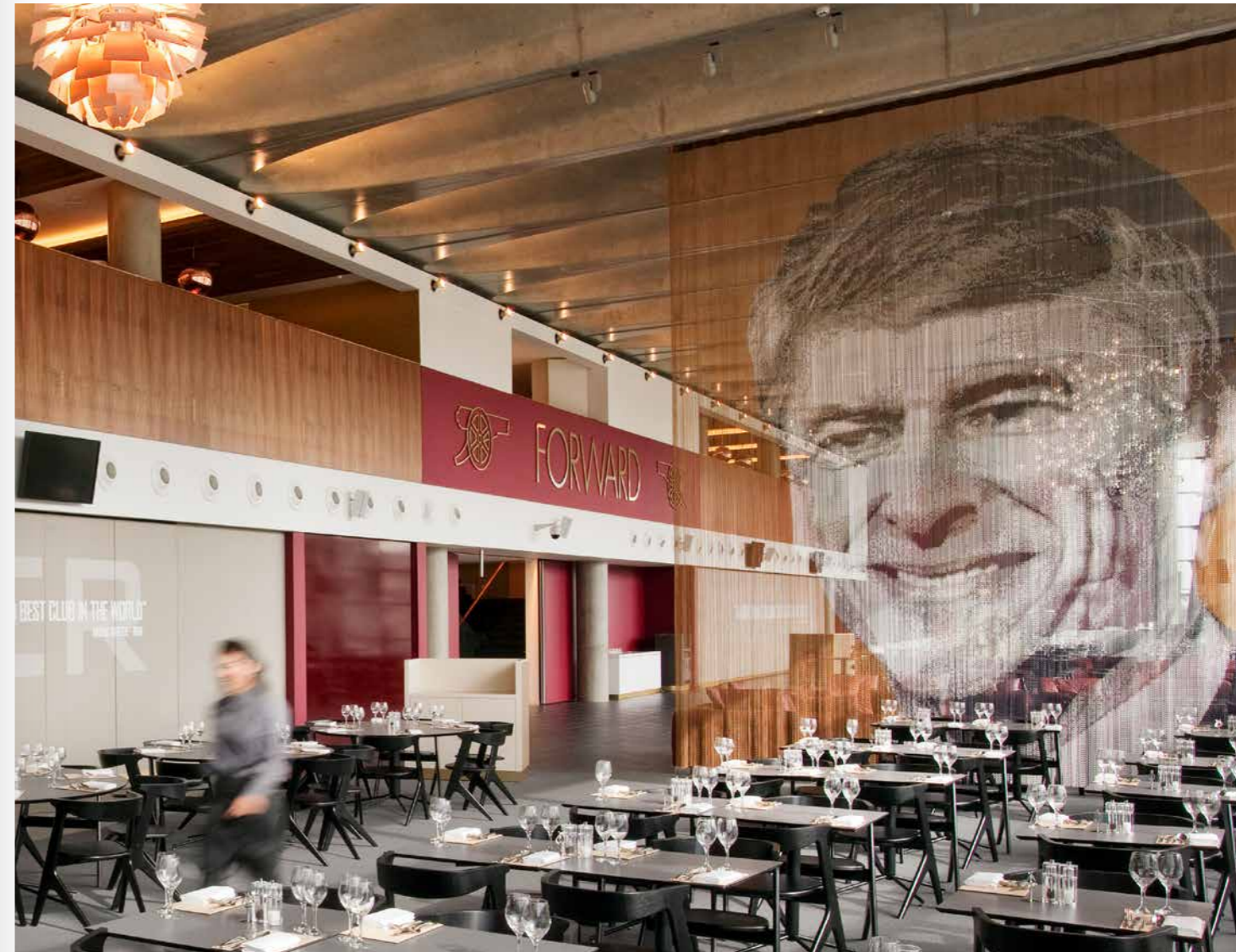

ARSENAL STADIUM

Project type Tipo de proyecto

Leisure Ocio

Design solution Solución de diseño

 Movable Móvil

Link Eslabón

 Kriska

Design Diseño

20|20 Design

Location Localización

London, UK



PHOTO BY MARCELA GRASSI

PAU CASALS VIP LOUNGE

Project type Tipo de proyecto

Public spaces Espacios públicos

Design solution Solución de diseño

 BCN Framed System

Link Eslabón

 Kriska

Design Diseño

Efebearquitectura

Location Localización

Barcelona Airport, Spain

3

Technical features Aspectos técnicos

IPG MEDIABRANDS

Project type Tipo de proyecto

Offices Oficinas

Design solution Solución de diseño

 Shaped Frame Shaped Frame

Link Eslabón

 Kriska

Design Diseño

Tétris Netherlands

Location Localización

Amsterdam, Netherlands

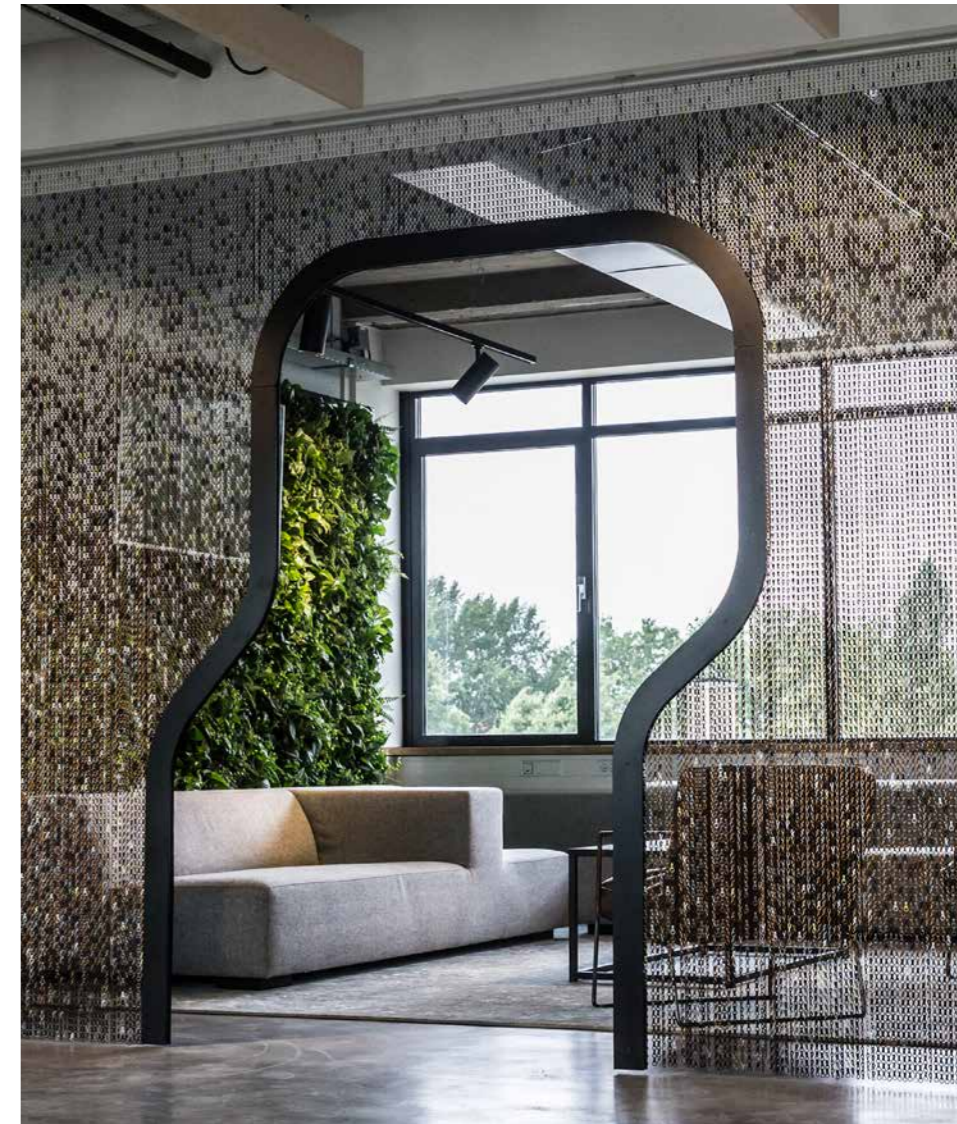

PHOTOS BY NIELS KRAMER



Straight · Curved · Undulated · Fixed · Movable

Decorating a wall never had so many creative possibilities. We create a technical solution for each space without any shape limits.

Wallcoverings Paredes

Rectas · Curvas · Onduladas · Fijas · Móviles

Decorar una pared nunca había tenido tantas posibilidades creativas. Creamos una solución técnica para cada espacio sin límite de forma.

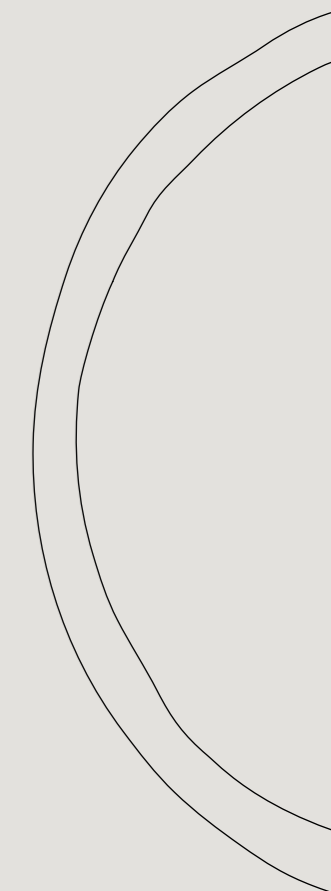
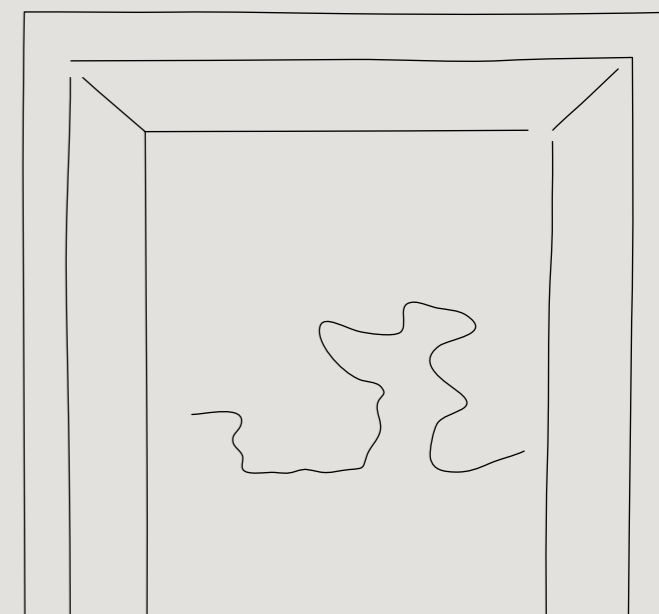
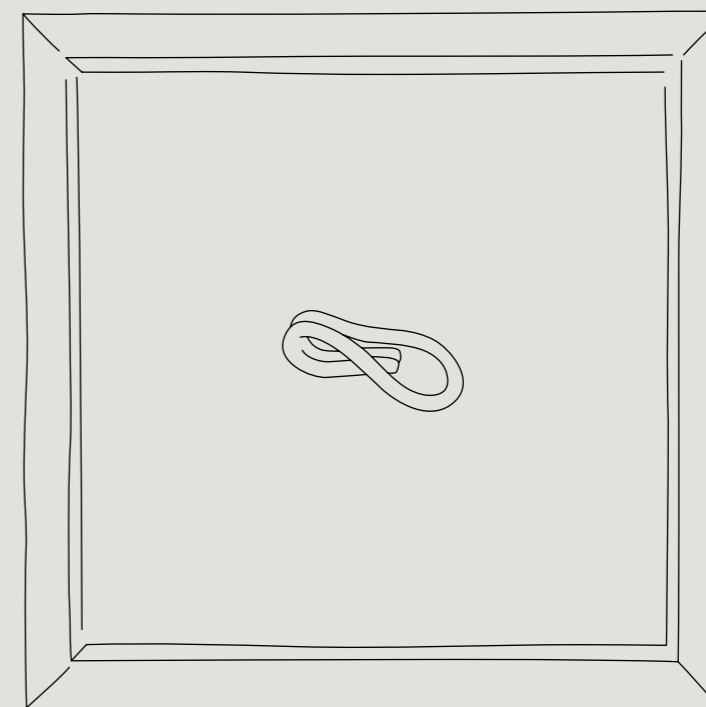

CASA BATLLÓ, GAUDÍ

Project type Tipo de proyecto

Public spaces Espacios públicos

Design solution Solución de diseño

Organic shapes Formas orgánicas

Link Eslabón

Kriska

Design Diseño

Kengo Kuma & Associates

Location Localización

Barcelona, Spain

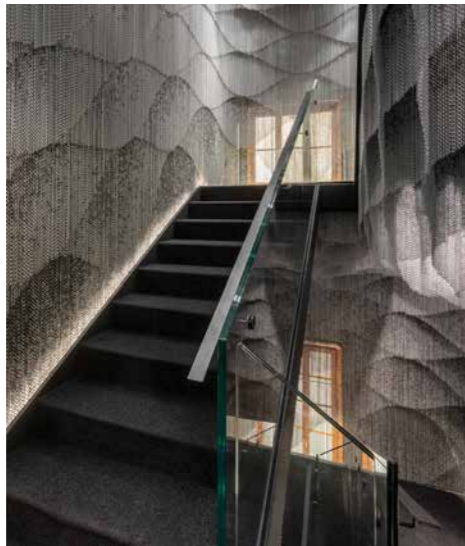

VIDEO VIDEO



PHOTOS BY JORDI ANGUERA

3

Technical features Aspectos técnicos

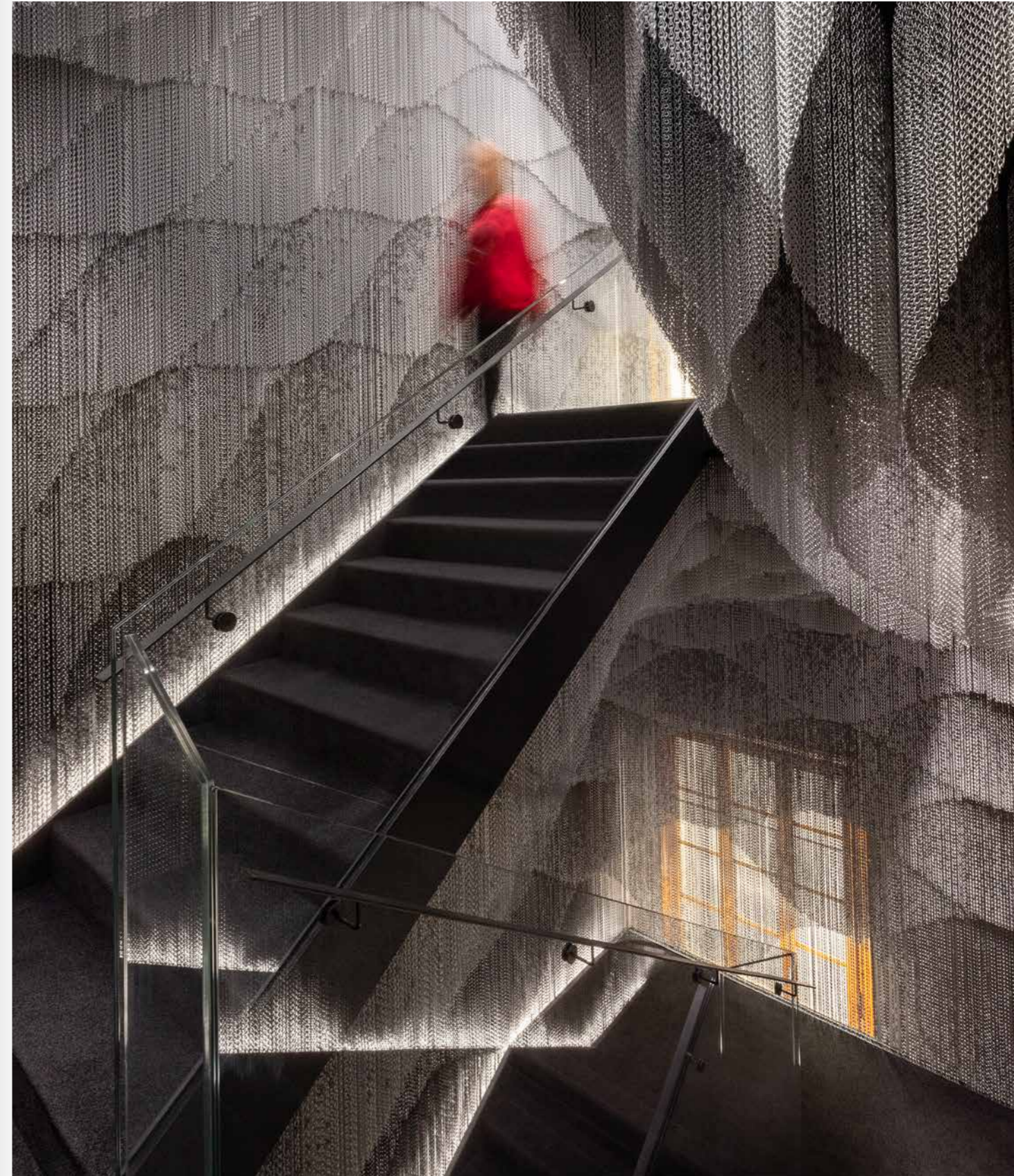

KOHAKINHO

Project type Tipo de proyecto

Hotels and restaurants Hoteles y restaurantes

Design solution Solución de diseño

— Straight Recta

Link Eslabón

 Kriska

Design Diseño

Bruno Huber Architects

Location Localización

Lugano, Switzerland



3

Technical features Aspectos técnicos



MARRIOTT RENAISSANCE WIEN

PHOTO BY DAVID BOHMANN

Project type Tipo de proyecto

Hotels and restaurants Hoteles y restaurantes

Design solution Solución de diseño

— Straight Recta

Link Eslabón

 Snina

Design Diseño

Christian Olufemi Architekten & Brumann
Innenraumkonzepte GmbH

Location Localización

Vienna, Austria



L'ANTIC TALLER

PHOTO BY MAURICIO FUERTES

Project type Tipo de proyecto

Hotels and restaurants Hoteles y restaurantes

Design solution Solución de diseño

— Straight Recta

Link Eslabón

🔗 Kriska

Design Diseño

Mireia Masdeu Studio

Location Localización

Barcelona, Spain

3

Technical features
Aspectos técnicos

CANALLA
DISCOTHEQUE

Project type Tipo de proyecto

Leisure Ocio

Design solution Solución de diseño

⤿ Curved Curva

Link Eslabón

🔗 Kriska

Design Diseño

Vailló+Irigaray Architects

Location Localización

Pamplona, Spain

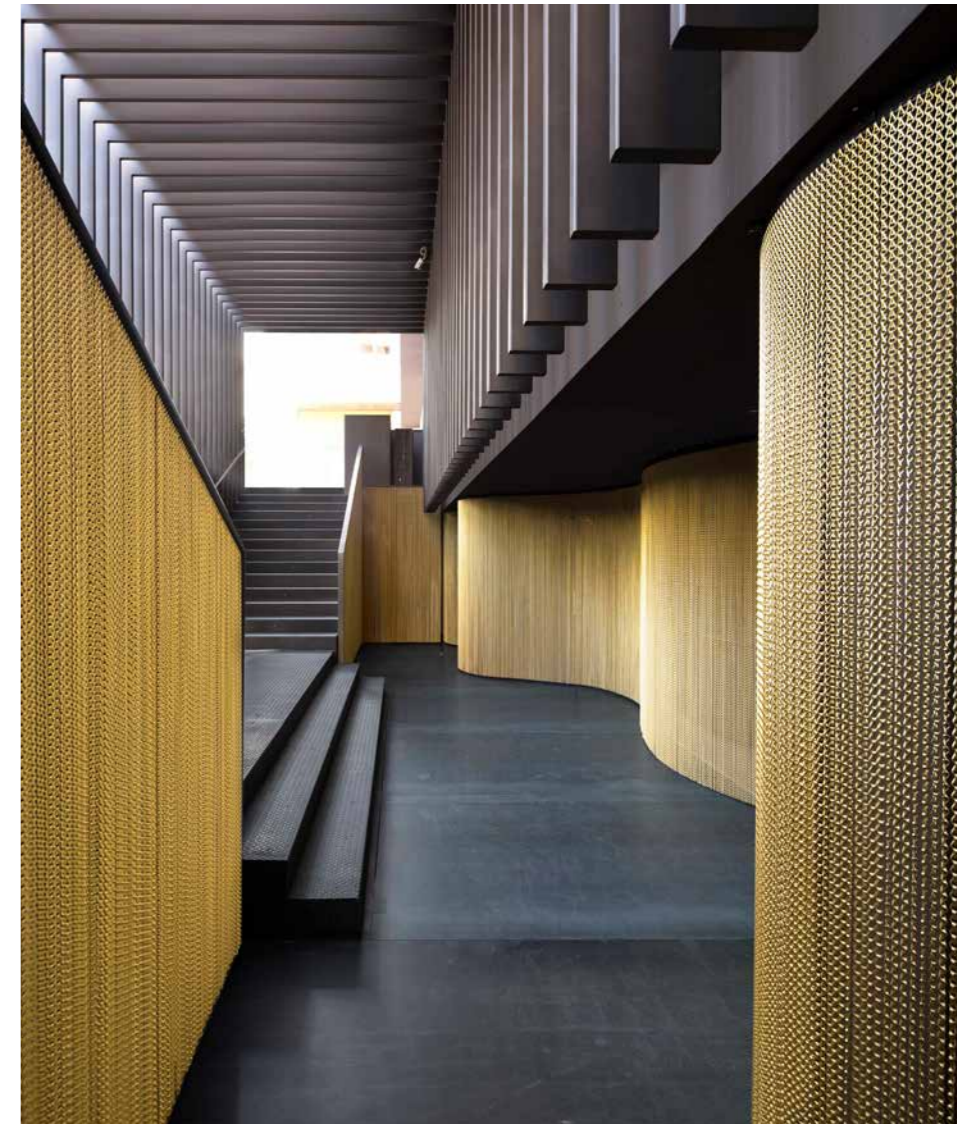

PHOTOS BY RUBÉN PÉREZ BESCÓS



NOVOTEL NEW YORK TIMES SQUARE

Project type Tipo de proyecto

Hotels and restaurants Hoteles y restaurantes

Design solution Solución de diseño

— Straight Recta

Link Eslabón

 Kriska

Design Diseño

Stonehill Taylor

Location Localización

New York City, NY, USA

3

Technical features Aspectos técnicos

KURZ&GUT MUNTANER

Project type Tipo de proyecto

Hotels and restaurants Hoteles y restaurantes

Design solution Solución de diseño

 Undulated Ondulada

Link Eslabón

 Kriska

Design Diseño

Pler Interioristas

Location Localización

Barcelona, Spain



PHOTOS BY MARCELA GRASSI

Parallel, straight or undulated compositions
Concentric squares or circles
Waves · Volume

With this architectural solution, we create astonishing compositions ranging from elegant waves and symmetrical structures to artistic shapes and personalised volumes. We can even create a rain-like effect.

Ceiling features Techos

Composiciones paralelas, rectas u onduladas
Concéntricas cuadradas o redondas
Ondas · Volumen

Con esta solución arquitectónica creamos composiciones sorprendentes, desde elegantes ondas o estructuras simétricas, hasta figuras artísticas y volúmenes personalizados. Incluso podemos recrear el efecto de la lluvia.



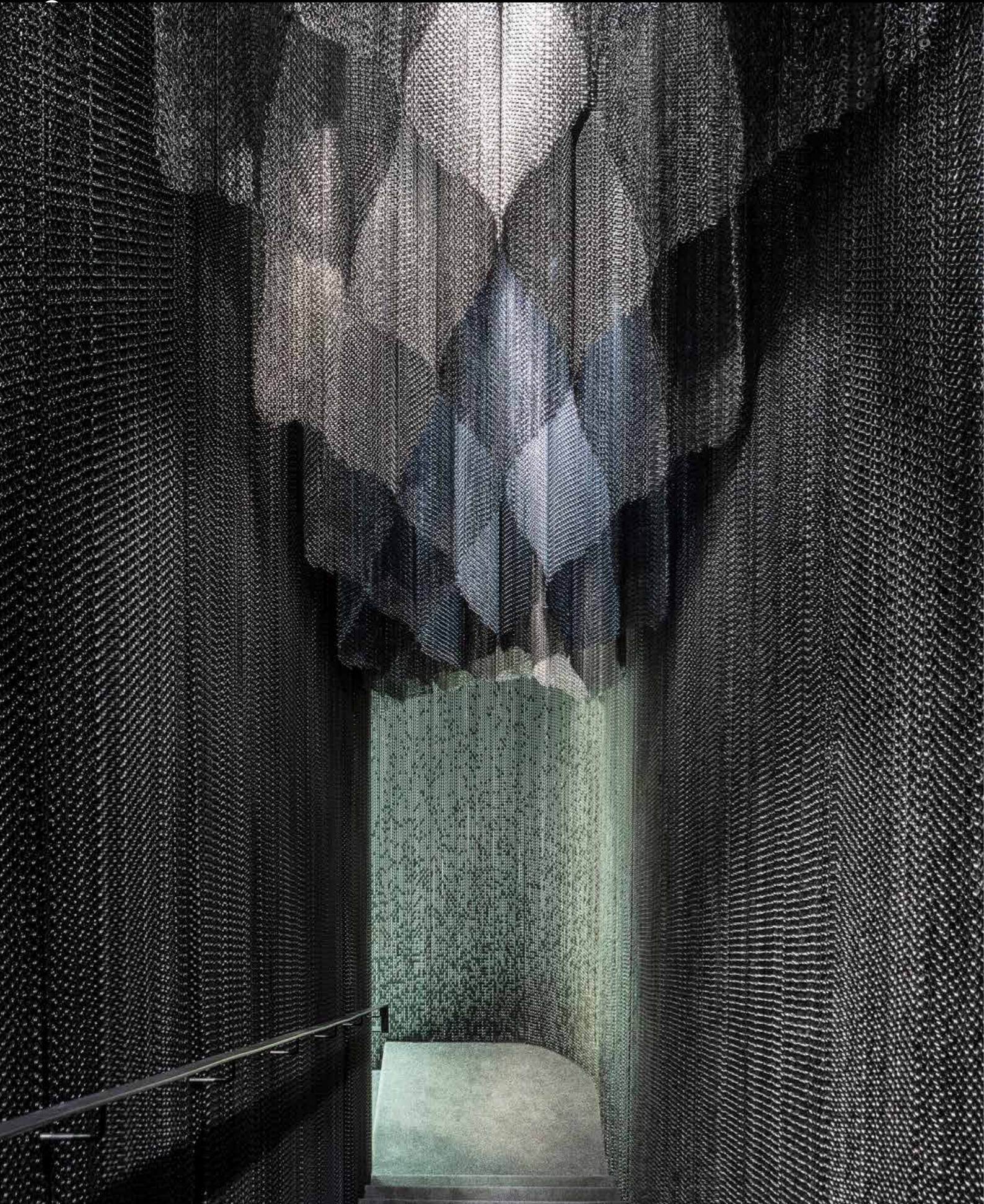

CASA BATLLÓ, GAUDÍ

Project type Tipo de proyecto

Public spaces Espacios públicos

Design solution Solución de diseño

 Organic shapes Formas orgánicas

Link Enlace

 Kriska

Design Diseño

Kengo Kuma & Associates

Location Localización

Barcelona, Spain



VIDEO VIDEO



PHOTOS BY JORDI ANGUERA

WESTFIELD MALL OF THE NETHERLANDS

Project type Tipo de proyecto

Stores and shopping malls
Tiendas y centros comerciales

Design solution Solución de diseño

Curved Curva

Link Eslabón

Kriska

Design Diseño

MVSA Architects

Location Localización

Leidschendam, Netherlands

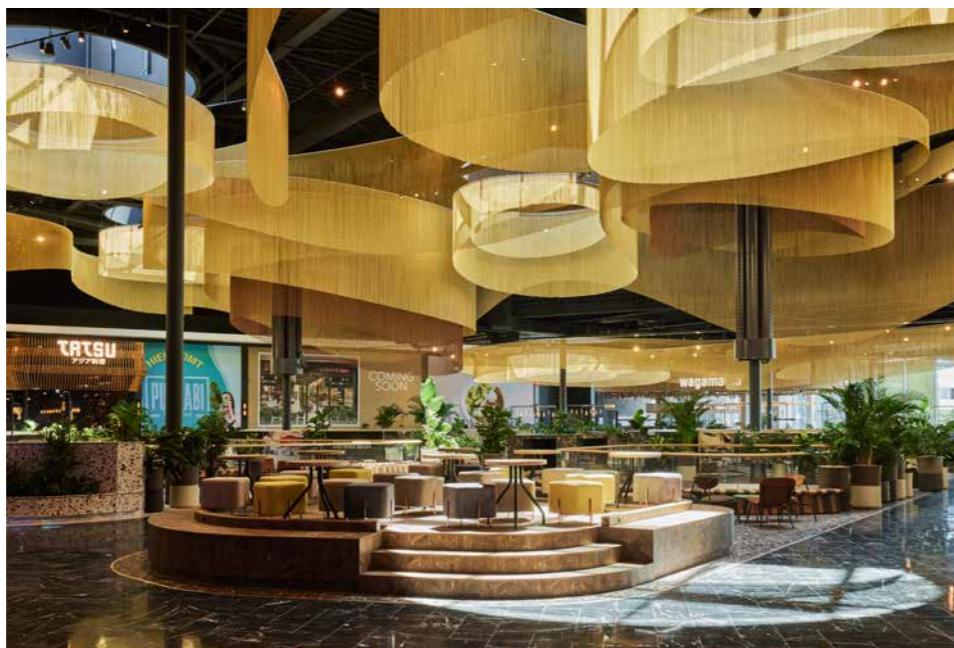

PHOTOS BY JONI ISRAELI

3

Technical features Aspectos técnicos



SORLI EMOCIONS

Project type Tipo de proyecto

Stores and shopping malls
Tiendas y centros comerciales

Design solution Solución de diseño

Parallel straight Paralelas rectas | Concentric round Concéntrica redonda

Link Eslabón

Kriska

Design Diseño

DYD interiorismo Chelo Alcañiz

Location Localización

Vilassar de Dalt, Spain

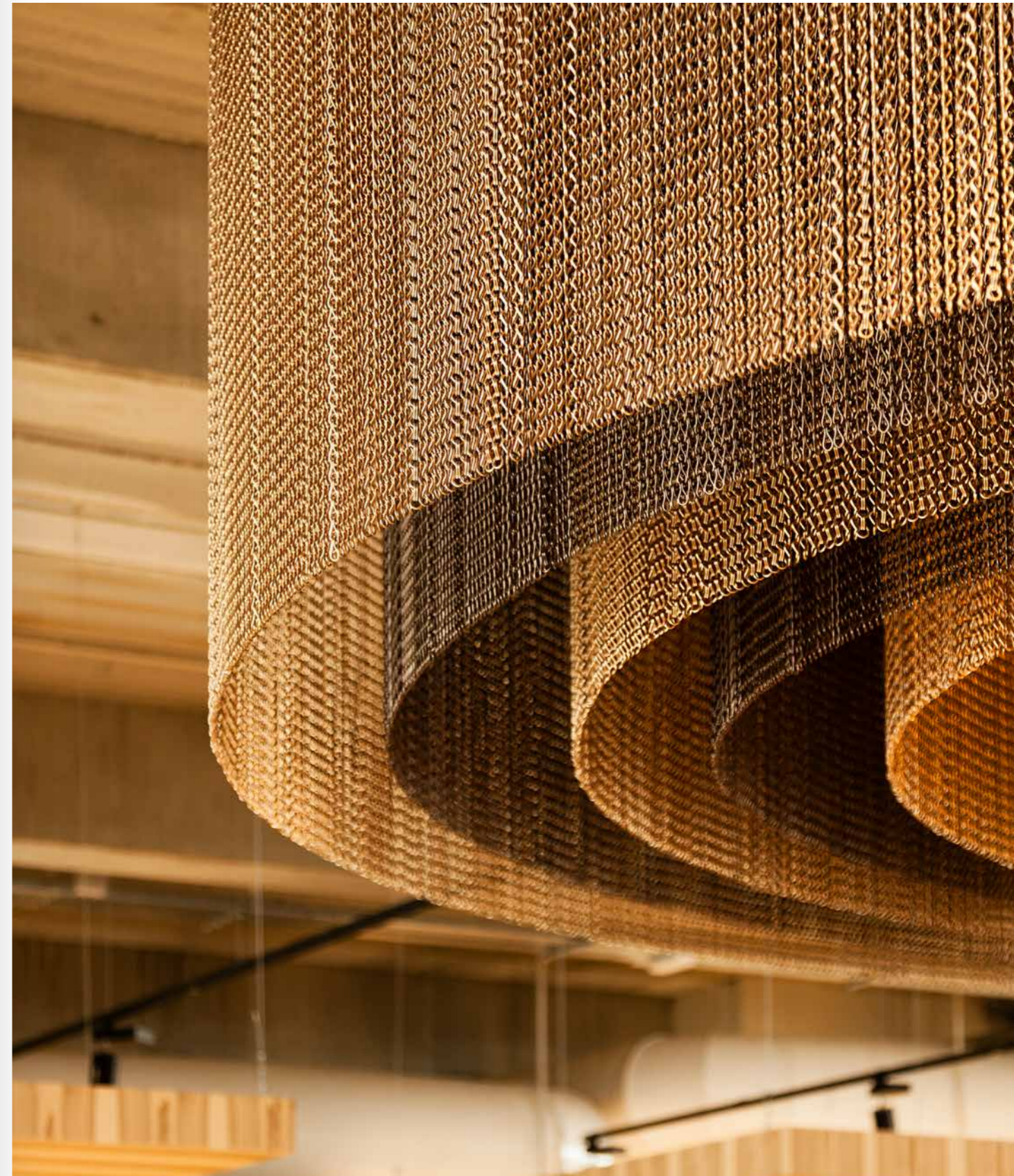

ALDGATE TOWER

Project type Tipo de proyecto

Offices Oficinas

Design solution Solución de diseño

 Cylindrical Cilíndrica

Link Eslabón

 Kriska

Design Diseño

Basha-Franklin

Location Localización

London, UK



PHOTOS BY PHILIP DURRANT

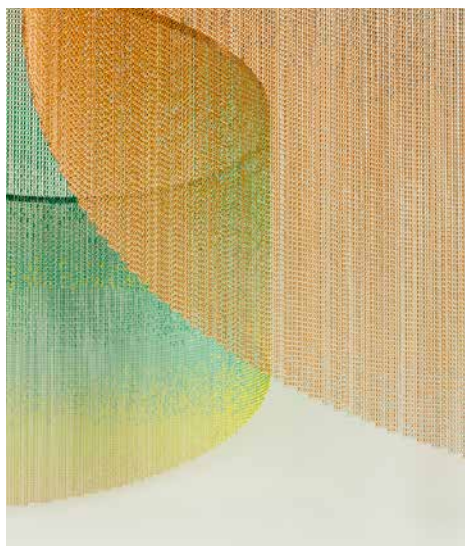

TALSEE SHOWROOM

Project type Tipo de proyecto

Stores and shopping malls
Tiendas y centros comerciales

Design solution Solución de diseño

 Volume Volumen

Link Eslabón

 Kriska

Design Diseño

Burkard Meyer Architekten & Konform

Location Localización

Hochdorf, Switzerland



NOVOTEL DIJON ROUTE DES GRANDS CRUS

Project type Tipo de proyecto

Hotels and restaurants Hoteles y restaurantes

Design solution Solución de diseño

 Curved Curva

Link Eslabón

 Kriska

Design Diseño

Design Studio

Location Localización

Marsannay-la-Côte, France

3

Technical features Aspectos técnicos

NOODLE HOUSE

Project type Tipo de proyecto

Hotels and restaurants Hoteles y restaurantes

Design solution Solución de diseño

 Concentric square Concéntrica cuadrada

Link Eslabón

 Snina

Design Diseño

LW Design

Location Localización

Moscow, Russia



WESTQUAY WATERMARK

Project type Tipo de proyecto

Stores and shopping malls
Tiendas y centros comerciales

Design solution Solución de diseño

Curved Curva

Link Eslabón

Kriska

Design Diseño

MTRDC Michelle Taylor

Location Localización

Southampton, UK

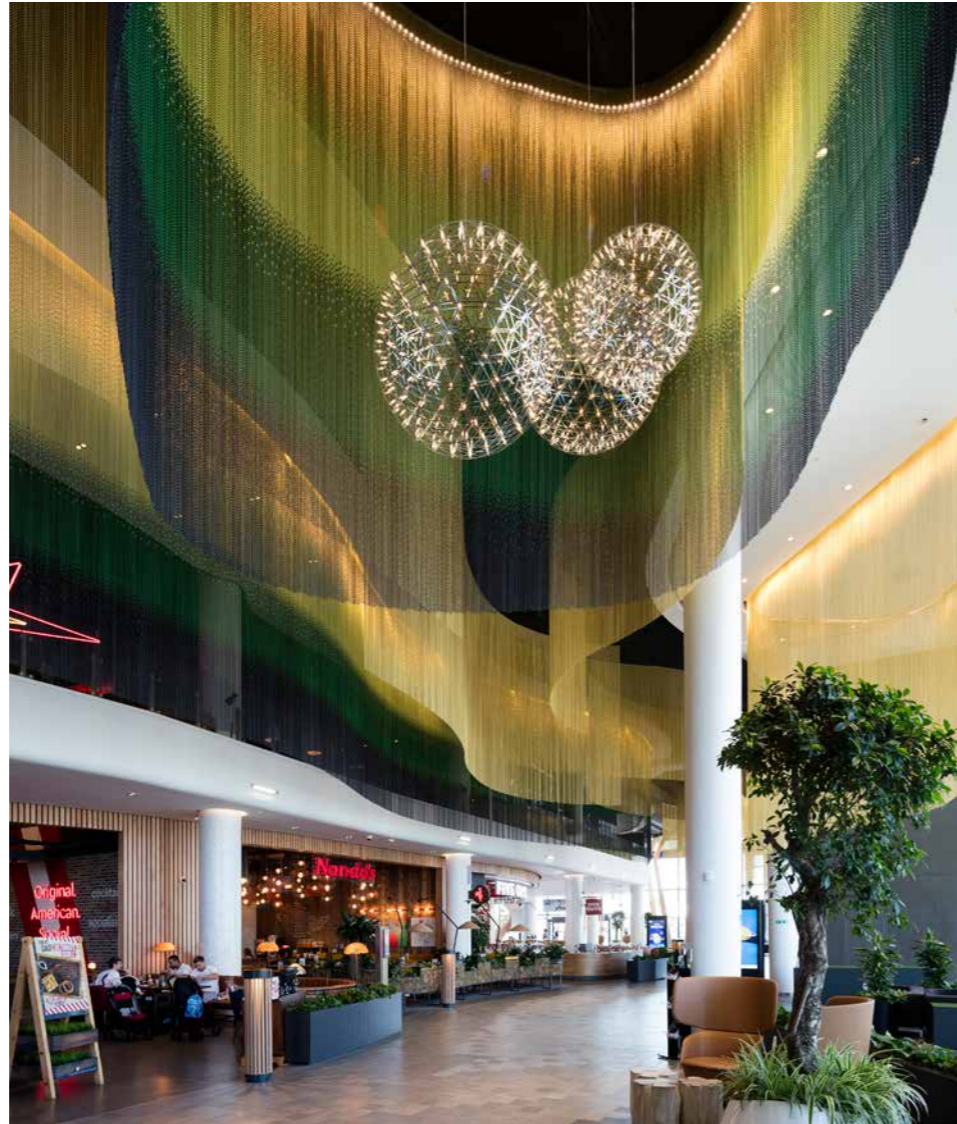

PHOTOS BY BEN LUXMOORE



3

Technical features Aspectos técnicos



FALLS

Design solution Solución de diseño

Organic shapes Formas orgánicas

Link Eslabón

Snina

Design Diseño

Yonoh Studio

Straight · Curved · Undulated

We can complement your project's lighting with our chains. We adapt to the geometry, size, and design you're looking for.

Lighting elements

Elementos de iluminación

Rectos · Curvos · Ondulados

Podemos complementar la iluminación de tu proyecto con nuestras cadenas. Nos adaptamos a la geometría, tamaño y diseño que estés buscando.

3

Technical features
Aspectos técnicos



KARAVAEVI CAFE

Project type Tipo de proyecto

Hotels and restaurants Hoteles y restaurantes

Design solution Solución de diseño

Undulated Ondulada
Concentric round Concéntrica redonda

Link Eslabón

Kriska

Design Diseño

Marina Bagrova

Location Localización

Moscow, Russia

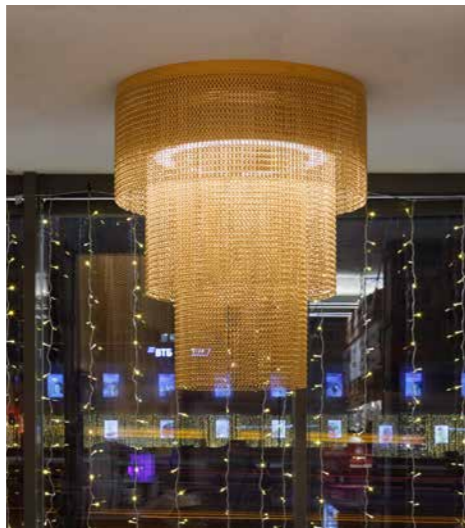

3

Technical features Aspectos técnicos

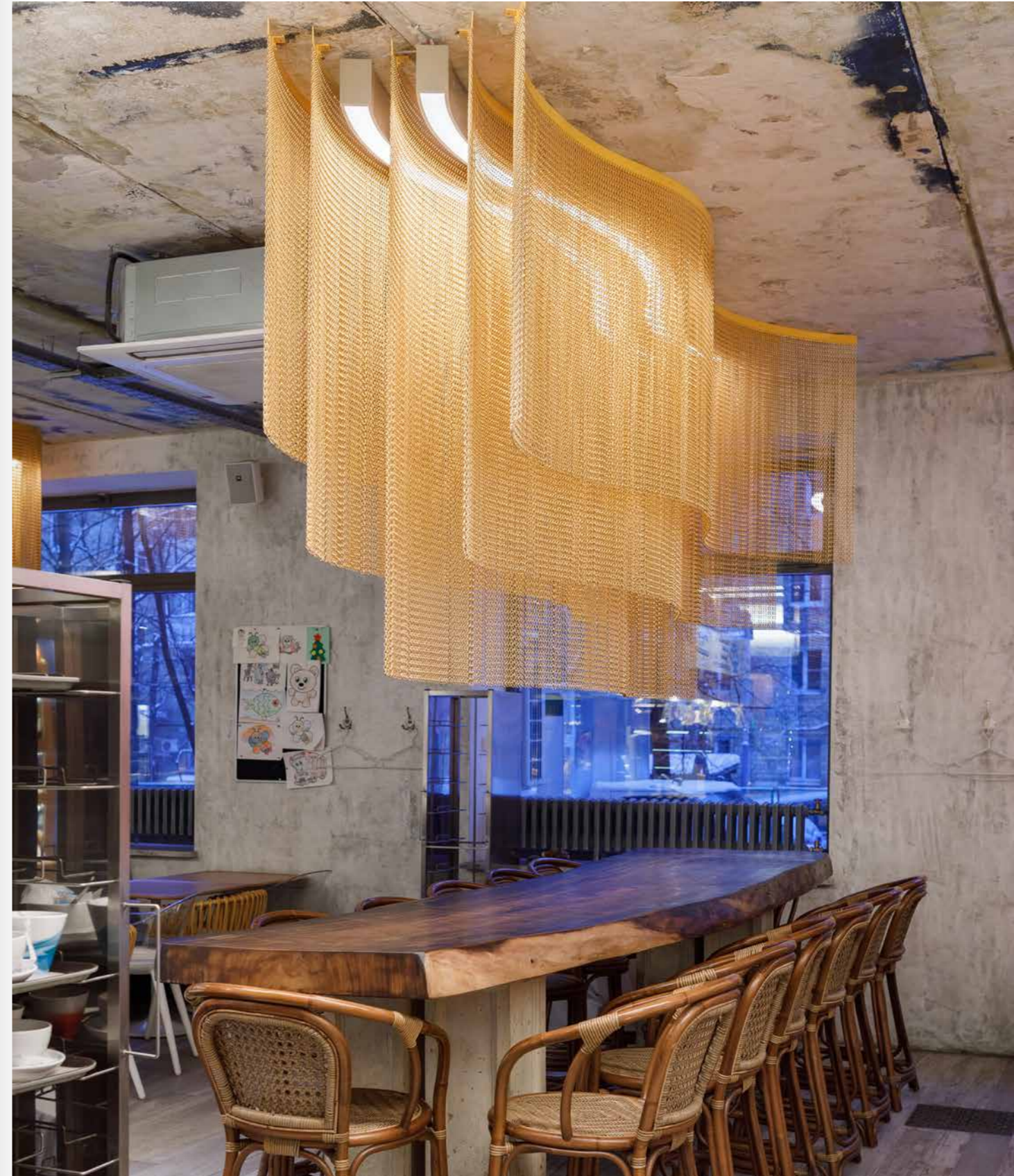

NANDO'S

Project type Tipo de proyecto

Hotels and restaurants Hoteles y restaurantes

Design solution Solución de diseño

 Cylindrical Cilíndrica

Link Eslabón

 Kriska

Design Diseño

Stac Architecture Ltd.

Location Localización

Altrincham, UK

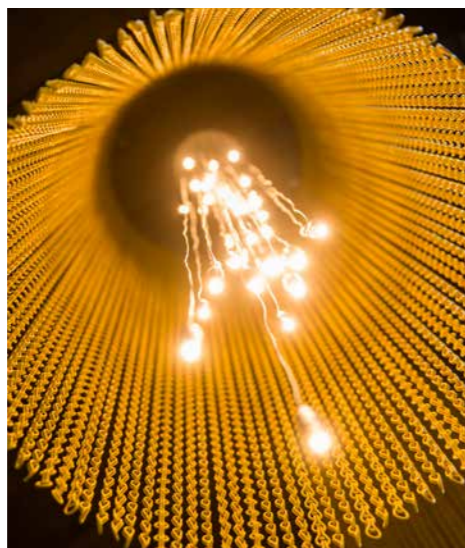

3

Technical features Aspectos técnicos



BURWELL'S STONE FIRE GRILL

Project type Tipo de proyecto

Hotels and restaurants Hoteles y restaurantes

Design solution Solución de diseño

 Cylindrical Cilíndrica

Link Eslabón

 Kriska

Design Diseño

Whitney Reitz Designs

Location Localización

Charleston, SC, USA



ALLUDE FLAGSHIP STORE

Project type Tipo de proyecto

Stores and shopping malls
Tiendas y centros comerciales

Design solution Solución de diseño

~ Ceiling waves Ondas de techo

Link Eslabón

Kriska

Design Diseño

Regina Dahmen-Ingenhoven

Location Localización

Kitzbühel, Austria



Outdoor · Indoor

A unique cladding system that enables the size and aesthetic of each project to be personalised, regardless of its size. If you envision a façade with a unique design that reproduces patterns, logos or even an image, we can make it happen.

Cladding

Revestimientos

Exterior · Interior

Una solución de revestimiento única que permite personalizar el tamaño y la estética de cada proyecto sin importar las dimensiones. Si habías imaginado una fachada con un diseño único, reproduciendo patrones, logos e incluso una imagen, nosotros podemos hacerlo realidad.

3

Technical features

Aspectos técnicos

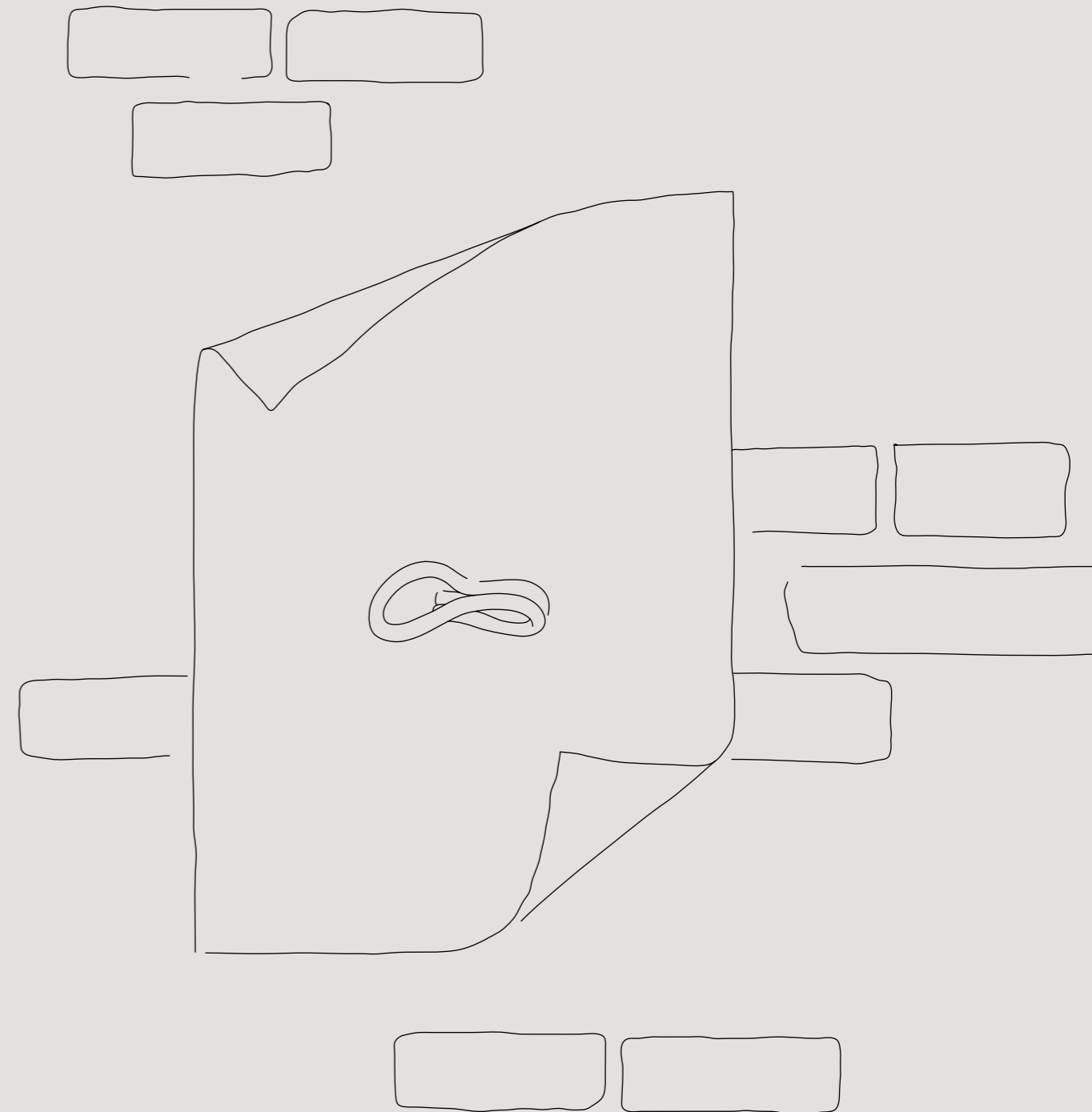

KI20 BUSINESS CENTRE

Project type Tipo de proyecto

Offices Oficinas

Design solution Solución de diseño

Indoor Interior

Link Eslabón	Measurements Medidas
	15 x 7 m
	105 m2 de cadena
	49.2 x 23 ft
	1130 sq ft of chain

Kriska

Design Diseño

MádiLáncos Studio

Location Localización

Budapest, Hungary

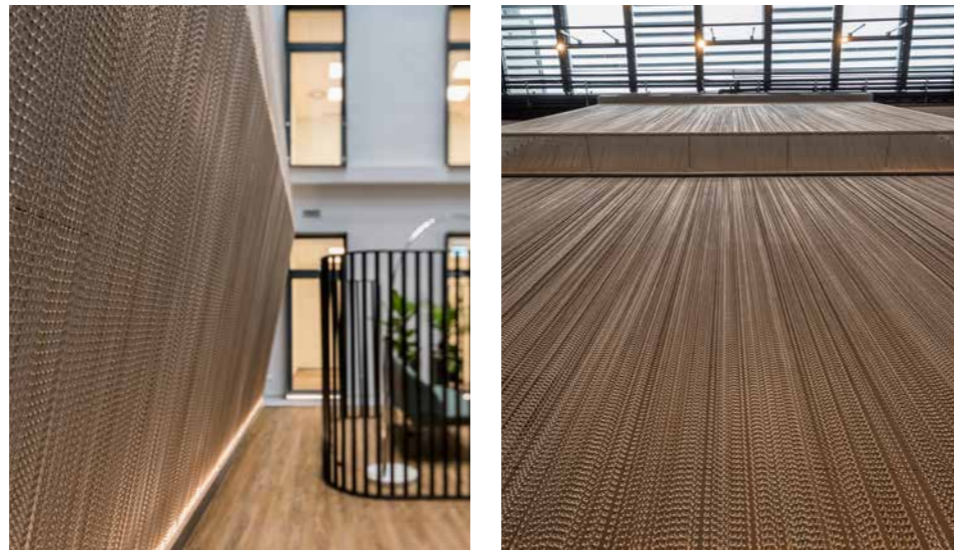

3

Technical features Aspectos técnicos

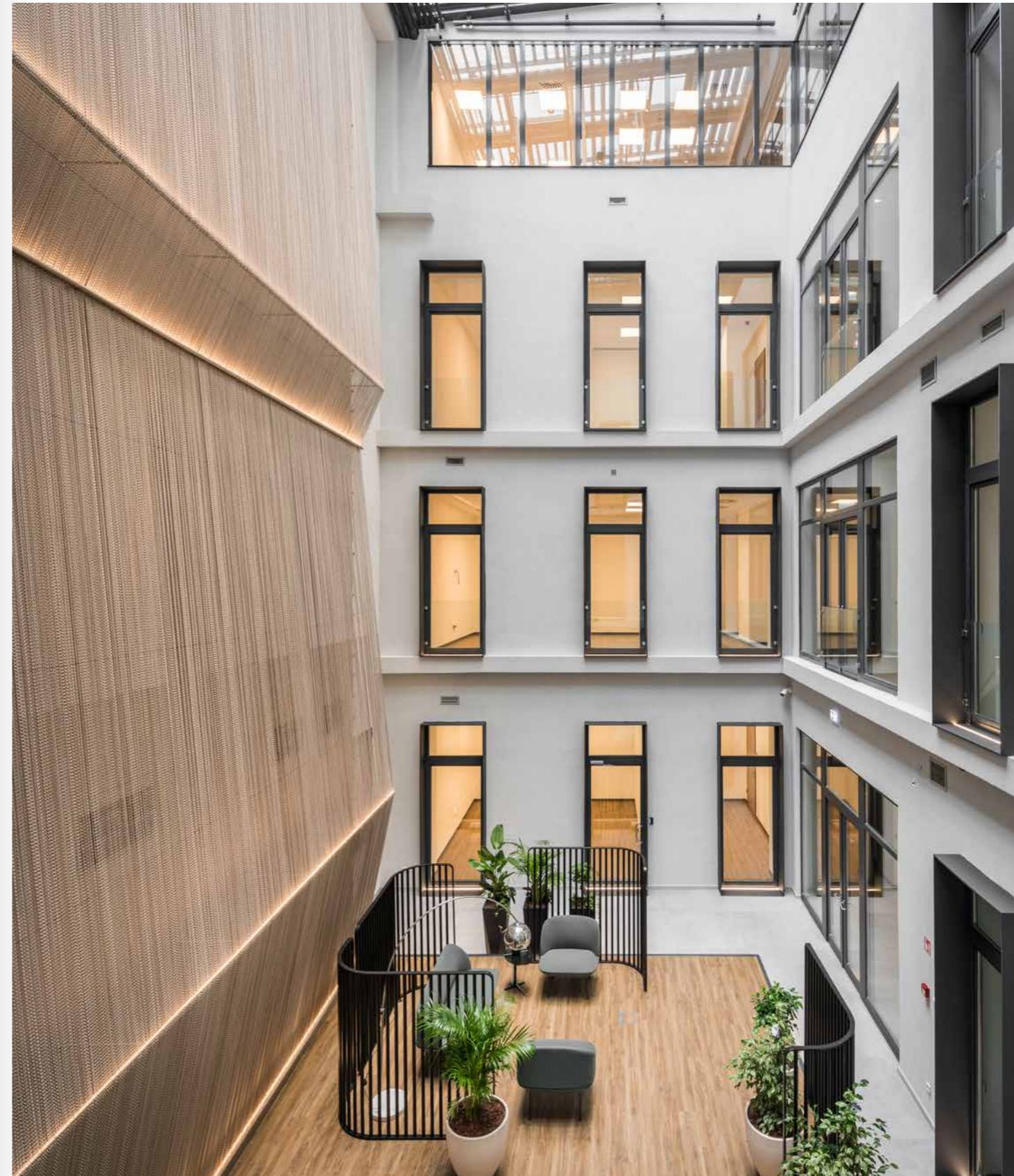

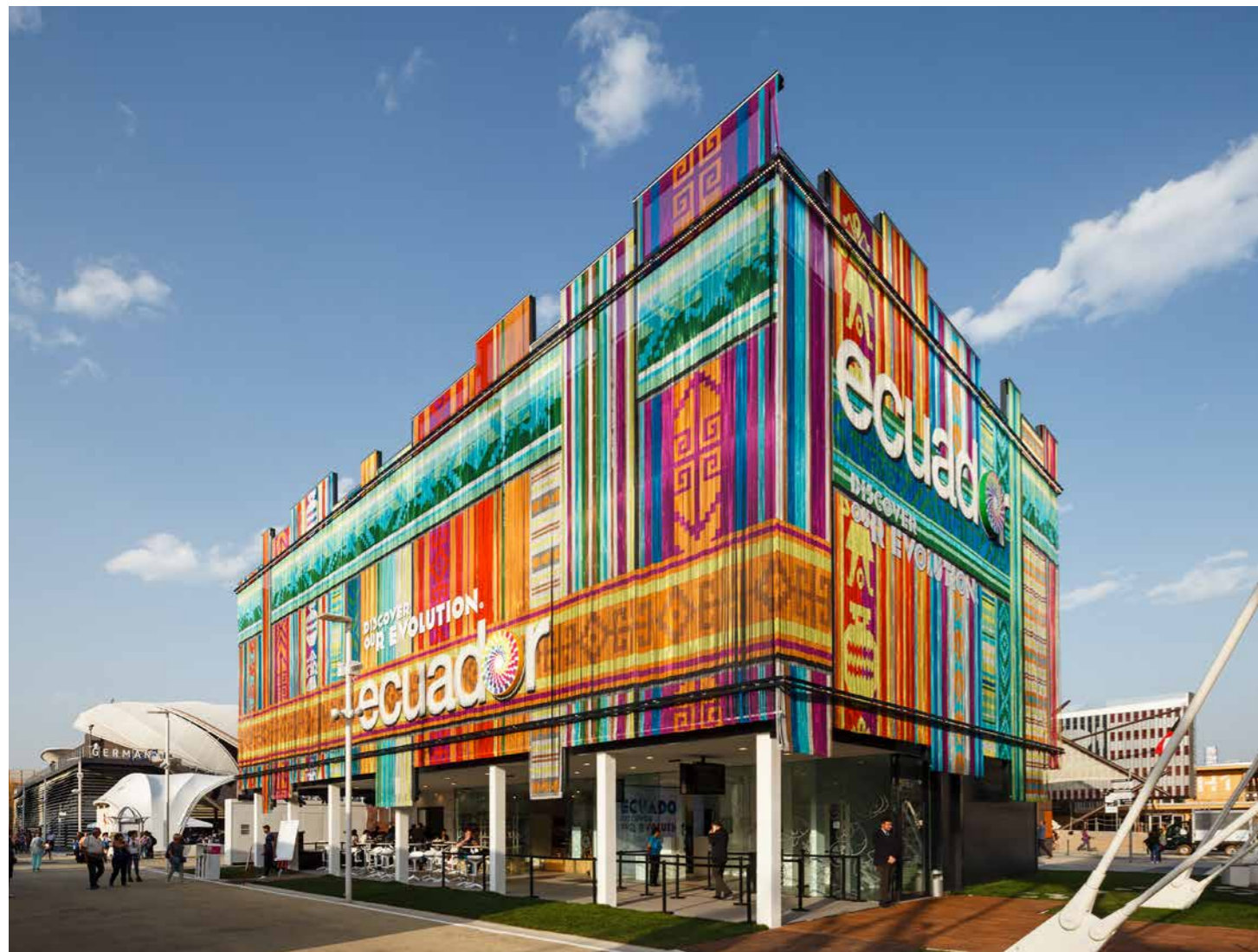

PHOTO BY MARCELA GRASSI

ECUADOR PAVILION MILAN EXPO 2015

Project type Tipo de proyecto

Stands and events Stands y eventos

Design solution Solución de diseño

 Outdoor Exterior

Link Eslabón	Measurements Medidas
	9 - 10,5 x 15 - 24,4 m
	756 m2 de cadena
	29,6-34,6 x 49,2-80 ft
 Kriska	8137,5 sq ft of chain

Design Diseño

Zorrozua y Asociados

Location Localización

Milan, Italy

VIDEO VIDEO



3

Technical features
Aspectos técnicos

ROYAL ASCOT HOTEL APARTMENT

Project type Tipo de proyecto

Hotels and restaurants Hoteles y restaurantes

Design solution Solución de diseño

 Indoor Interior

Link Eslabón	Measurements Medidas
	40 x 8 m
	320 m2 de cadena
	131,2 x 26,3 ft
 Kriska	3444 sq ft of chain

Design Diseño

Sven Müller

Location Localización

Dubai, UAE



CAN MANENT

Project type Tipo de proyecto

Public spaces Espacios públicos

Design solution Solución de diseño

 Outdoor Exterior

Link Eslabón	Measurements Medidas
	5 - 6 x 80 m
	400 m2 de cadena
	16.4-19.7 x 262.5 ft
 Kriska	4306 sq ft of chain

Design Diseño

Fran Fernández, Fina Frontado
Saida Dalmau

Location Localización

Cardedeu, Spain



PHOTOS BY RAMIRO ELENA



3

Technical features Aspectos técnicos



PHOTO BY MARCELA GRASSI

ARCHIPRODUCTS MILANO

Project type Tipo de proyecto

Public spaces Espacios públicos

Design solution Solución de diseño

 Outdoor Exterior

Link Eslabón	Measurements Medidas
	4,815 x 13 m
	63 m2 de cadena
	15.8 x 42.7 ft
 Kriska	678 sq ft of chain

Design Diseño

Serena Confalonieri

Location Localización

Milan, Italy



PLAYASOL JABEQUE SOUL IBIZA

Project type Tipo de proyecto

Hotels and restaurants Hoteles y restaurantes

Design solution Solución de diseño

 Indoor Interior

Link Eslabón

Measurements Medidas

9 curtains 12,5 x 1,5 m

170 m2 de cadena

9 curtains 41 x 4.9 ft

1830 sq ft of chain

 Kriska

Design Diseño

Aixut Interiorisme

Location Localización

Ibiza, Spain



Scenography · Events · Exhibitions · Stands · Art

Thanks to our enormous flexibility and experience, we can create surprising artistic and ephemeral installations.

Just test our limits!

Other uses

Otros usos

Escenografía · Eventos · Exposiciones · Stands · Arte

Gracias a nuestra gran flexibilidad y experiencia podemos crear sorprendentes instalaciones artísticas y efímeras.

¡Pon a prueba nuestros límites!

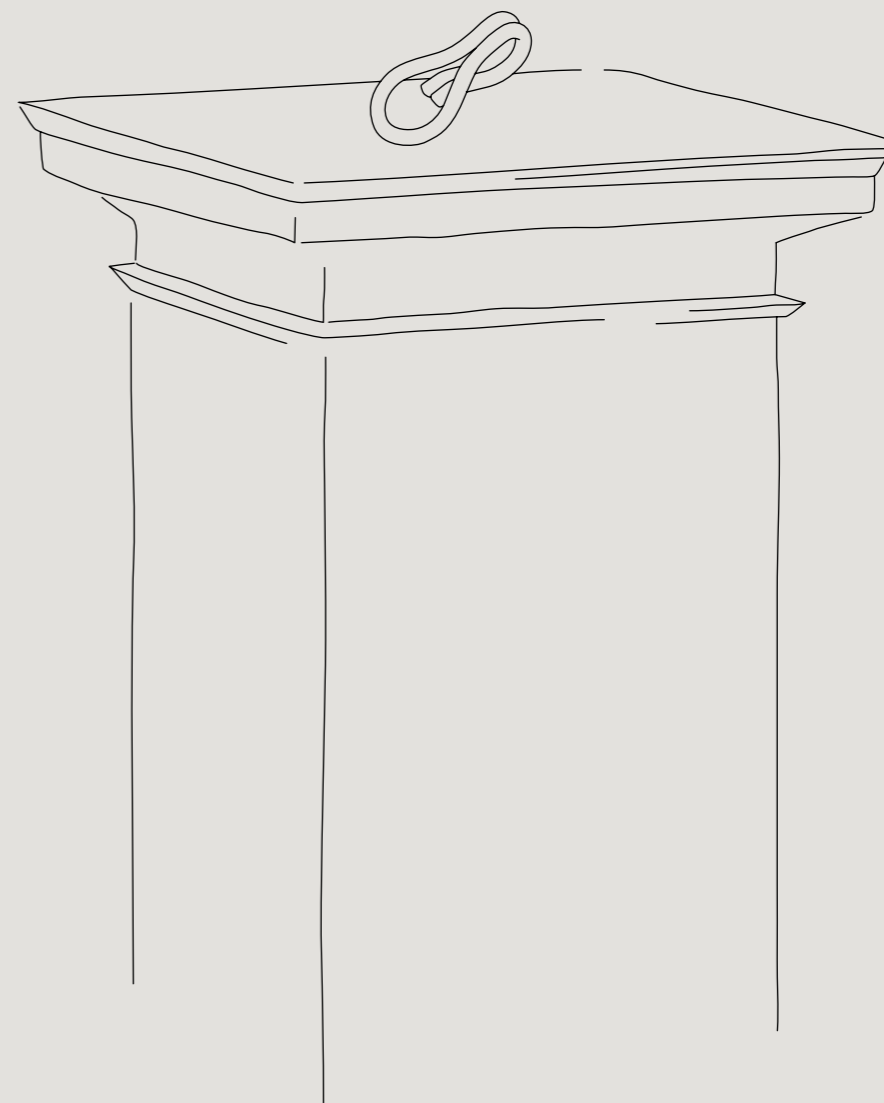



“BALDAQUÍ”, FESTIVAL A CEL OBERT 2019

Project type Tipo de proyecto

Ephemeral architecture Arquitectura efímera

Design solution Solución de diseño

Special structure Estructura especial

Link Enlace

Kriska

Design Diseño

Joan Bardy & Jean Orliac

Location Localización

Tortosa, Spain

Awards Premios

Jury Award Premio del Jurado





BARÇA STORE

PHOTO BY MARCELA GRASSI

Project type Tipo de proyecto

Stores and shopping malls

Tiendas y centros comerciales

Design solution Solución de diseño

 Shaped Frame

Link Eslabón

 Kriska

Design Diseño

García Capella Arquitectura

Location Localización

Barcelona Airport, Spain

3

Technical features Aspectos técnicos

“LA NIT DE ST. JOAN”, DAGOLL DAGOM

Project type Tipo de proyecto

Scenography Escenografía

Design solution Solución de diseño

— Straight Recta

Link Eslabón

 Kriska

Design Diseño

Montse Amenós & Isidre Prunés

Location Localización

Barcelona, Spain



CASA DECOR VALENCIA 2008

Project type Tipo de proyecto

Stands and events Stands y eventos

Design solution Solución de diseño

Volume Volumen

Link Eslabón

Kriska

Design Diseño

Ivan Martínez

Location Localización

Valencia, Spain



PHOTOS BY CASA DECOR



3

Technical features Aspectos técnicos

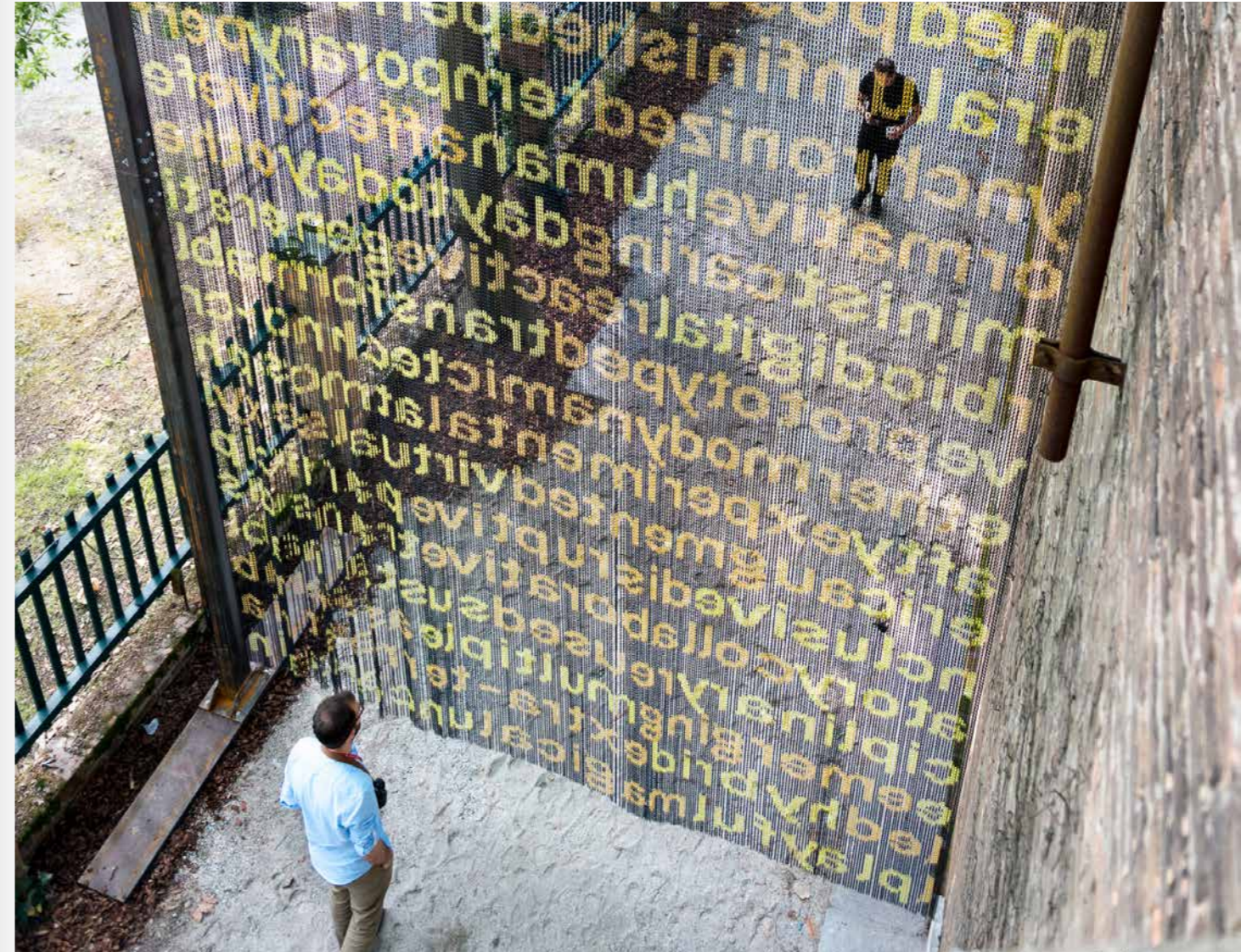

PHOTO BY ANA MATOS

“COME-IN”, BIENNALE ARCHITETTURA 2018

Project type Tipo de proyecto

Stands and events Stands y eventos

Design solution Solución de diseño

Straight Recta

Link Eslabón

Kriska

Design Diseño

Ana Matos & Antonio Samaniego

Location Localización

Venice, Italy



“/(-\”, NUNO CENTENO GALLERY 2013

Project type Tipo de proyecto

Art Arte

Design solution Solución de diseño

 Shaped Frame Shaped Frame

Link Eslabón

 Kriska

Design Diseño

Daniel Steegman

Location Localización

Porto, Portugal



3

Technical features
Aspectos técnicos

**“WELCOME” -
ESTADO DE SITIO,
SALA AMÓS SALVADOR**

Project type Tipo de proyecto

Art Arte

Design solution Solución de diseño

— Straight Recta

Link Eslabón

 Snina

Design Diseño

Carlos Aires Studio

Location Localización

Logroño, Spain

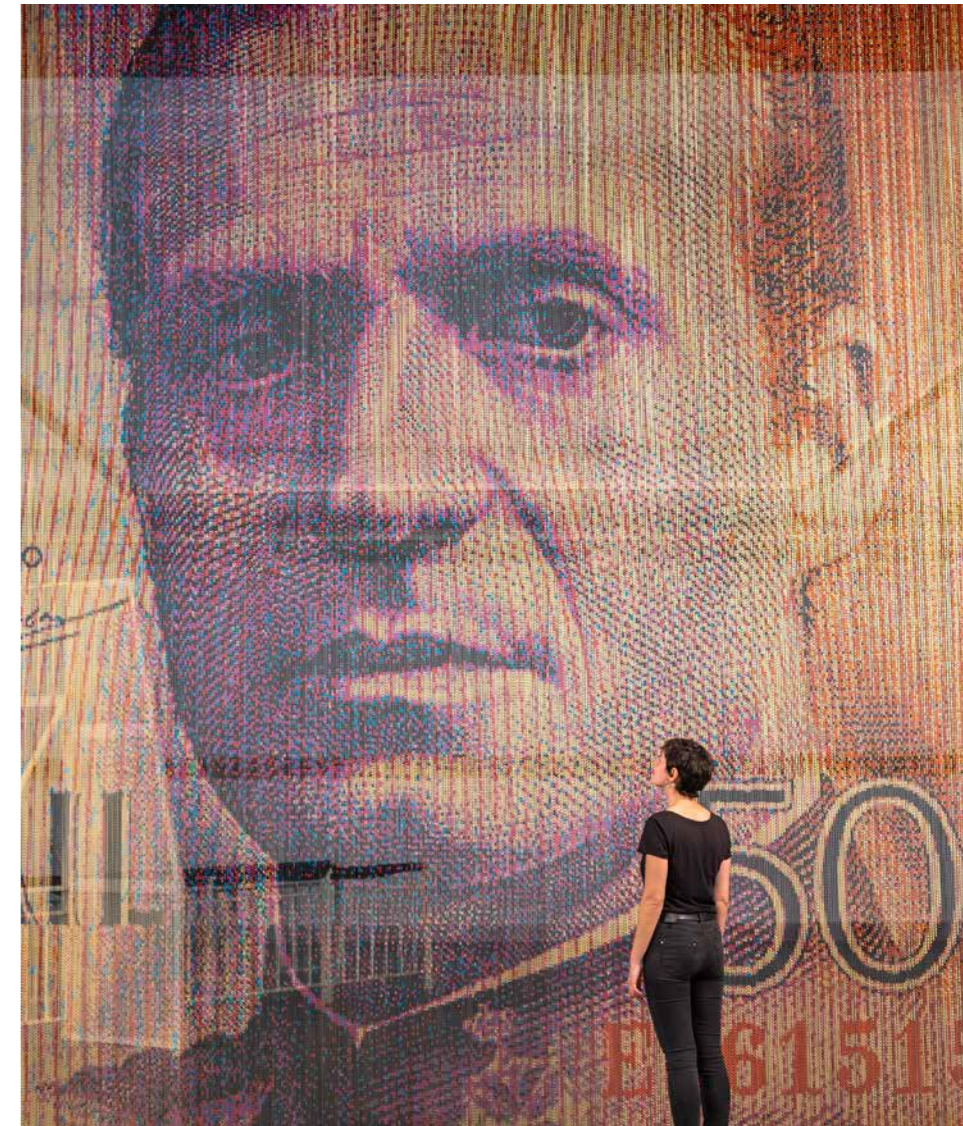

PHOTOS BY RAFAEL LAFUENTE & SALA AMÓS SALVADOR

EUROSHOP 2020

Project type Tipo de proyecto

Stands and events Stands y eventos

Design solution Solución de diseño

Special structure Estructura especial

Link Eslabón

Snina

Design Diseño

Studio Animal

Location Localización

Düsseldorf, Germany

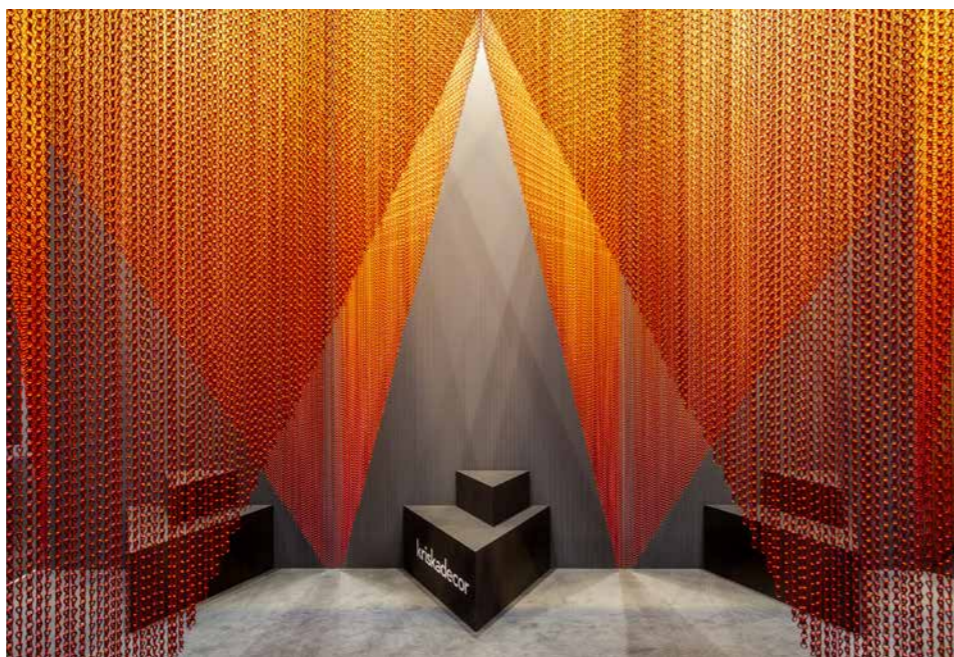

3

Technical features Aspectos técnicos



PARKING INFRARROJO, ODISEO CENTRO DE OCIO

Project type Tipo de proyecto

Leisure Ocio

Design solution Solución de diseño

Special structure Estructura especial

Link Eslabón

Kriska

Design Diseño

Clavel Arquitectos

Location Localización

Murcia, Spain

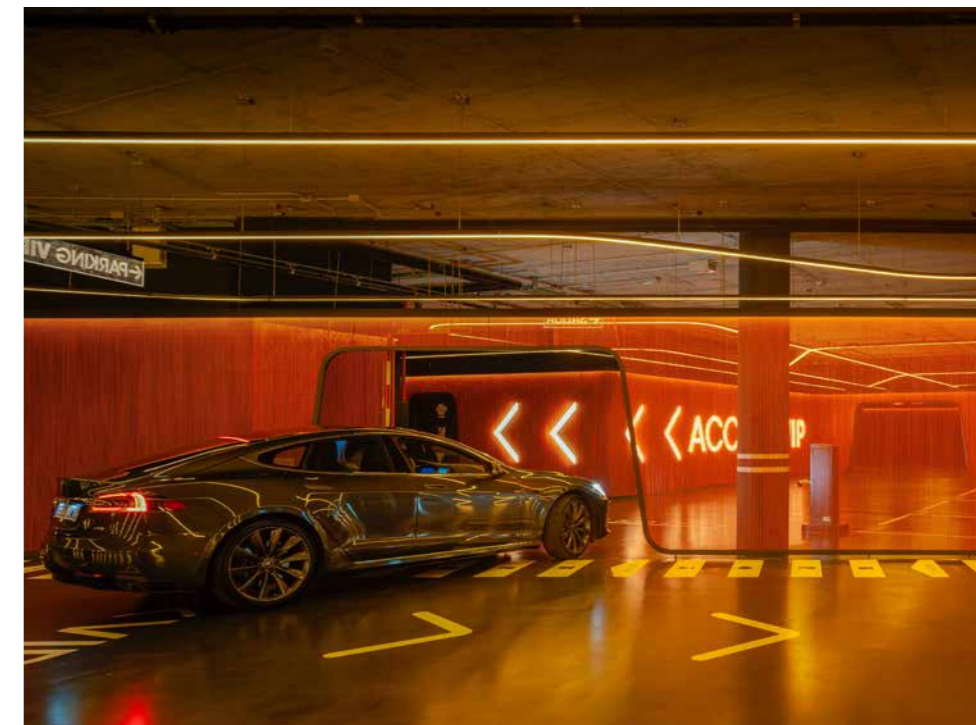

Aura · BCN Screen Divider · Boira Planter

In keeping with Kriskadecor's philosophy, we have developed highly customisable designer collections.

Products Productos

Aura · Biombo BCN · Jardinera Boira

Siguiendo la filosofía de Kriskadecor, hemos desarrollado colecciones de diseño de autor altamente personalizables.

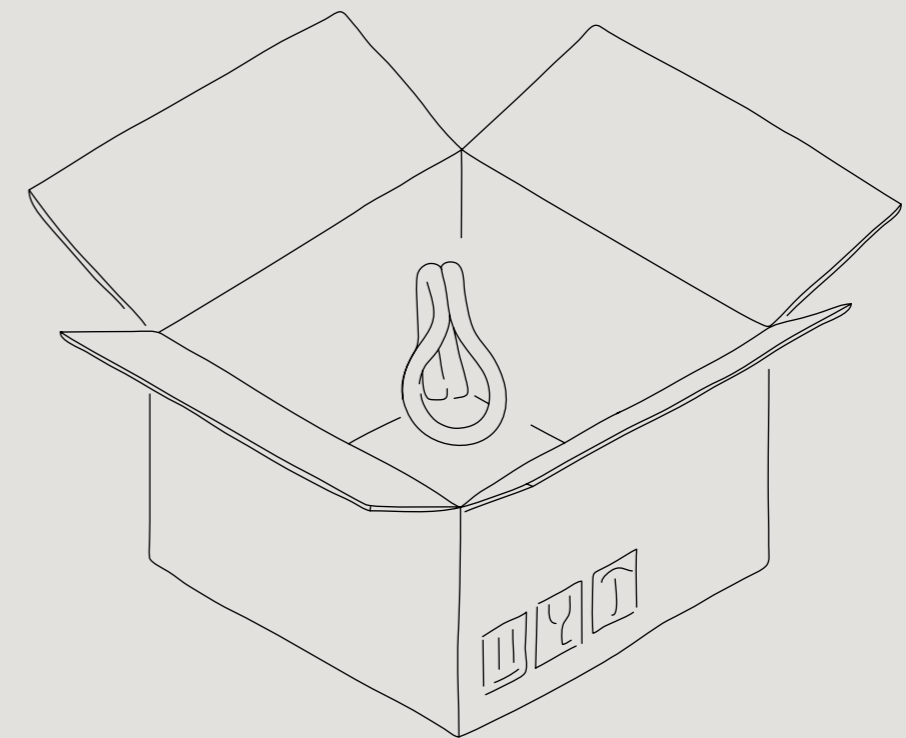

AURA

BY YONOH STUDIO



reddot award 2019
winner

With the design of the Aura Collection, Yonoh has managed to create a lighting system combining tubular chain structures that result in a unique sculptural effect.

Could you have imagined lighting with so many possibilities?

Con el diseño de Aura Collection, Yonoh ha conseguido crear un sistema lumínico que combina estructuras tubulares de cadena que generan un efecto escultórico único.

¿Imaginabas una iluminación con tantas posibilidades?



BEST of year
WINNER 2018



3

Technical features Aspectos técnicos



Aura One



Aura Two



Aura Three



Aura Four



Aura Five



Aura Floor

Tube length

Longitud de los tubos

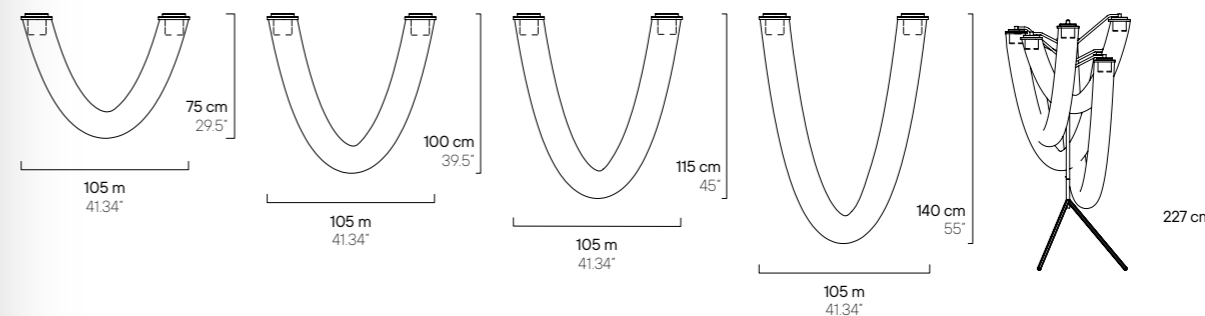

*
Aura Floor not
available in the USA
Aura Floor no
disponible para EUA

Materials and finishes

Materiales y acabados

STRUCTURE ESTRUCTURA



RAL 9005
Jet black
Negro intenso

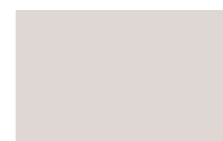

RAL 9010
Pure white
Blanco puro



Manufactured with Snina.
Fabricado con Snina.

Lacquered aluminium.
The colours can be personalised upon request.
Handmade borosilicate glass diffuser with matte opal finish.
Abstract designs can be reproduced.
Aluminio lacado.
Los colores pueden personalizarse bajo petición.
Difusor de vidrio de borosilicato con acabado opal mate hecho a mano.
Es posible reproducir diseños abstractos.

Measurements

Medidas

We can also create different tube combinations to meet our clients' needs.
También es posible crear diferentes combinaciones de tubos que se adapten a las necesidades de nuestros clientes.

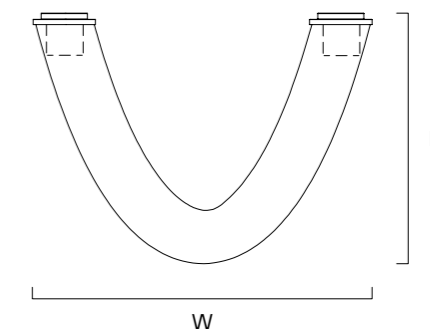

BCN SCREEN DIVIDER

BY CREA PRODUCT DESIGN

This screen fits perfectly into any environment thanks to the many customisation possibilities in terms of sizes and finishes. In addition, it comes with a spring that keeps the chains fixed and taut at all times.

Este biombo encaja perfectamente en cualquier ambiente gracias a sus amplísimas posibilidades de personalización en medidas y acabados. Además, incorpora un sistema de muelles que permite que las cadenas se mantengan fijas y tensadas en todo momento.



3

Technical features Aspectos técnicos

Materials and finishes Materiales y acabados

PROFILE PERFIL



Noir 900 sablé
Texturized



Ral 7047
Grey shiny

Lacquered aluminium.
Custom RAL colours upon request.
Aluminio lacado.
Colores RAL personalizados bajo petición.

Compositions Composiciones

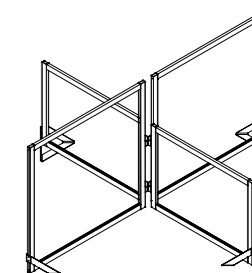
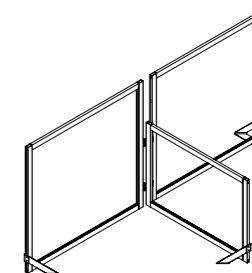
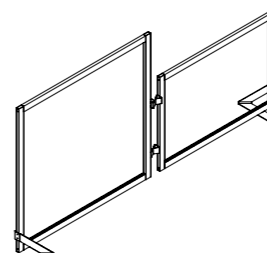

Designs & patterns Diseños y patrones

You can choose a pattern from the Collection catalogue or suggest your own design with brilliant or satin finishes.

Se puede elegir un patrón del catálogo Collection o sugerir un diseño propio en colores brillantes o satinados.



Manufactured with Snina.
Fabricado con Snina.

Measurements Medidas

Standard options. Sizes can be customised upon request.
Opciones estándar. Las medidas se pueden personalizar bajo petición.

Mesasurements Medidas	Width Ancho	Height Alto	Depth Fondo
S	1,62 m 63 3/4"	1,20 m 47 1/4"	0,40 m 15 3/4"
M	1,22 m 48"	1,60 m 63"	0,40 m 15 3/4"
L	1,42 m 55 7/8"	1,80 m 70 7/8"	0,47 m 18 1/2"

BOIRA PLANTER

BY KRISKADECOR & HOBBY FLOWER

Kriskadecor and Hobby Flower have worked together to create Boira, a space divider that includes a patented self-watering system that, not only faithfully reproduces a natural plant environment, but also allows for 80% water savings per year.

The Snina chain link allows the piece to be adapted to the project's needs.

Kriskadecor y Hobby Flower han trabajado en equipo para crear Boira, un separador de espacios que incluye un sistema de autorriego patentado que, además de reproducir fielmente el entorno natural de las plantas, permite ahorrar un 80% en agua de riego al año.

El eslabón Snina permite adaptar la pieza a las necesidades del proyecto.



3

Technical features Aspectos técnicos

Materials and finishes Materiales y acabados

STANDARD COLOURS COLORES ESTÁNDAR



Corten
Corten

Lead
Plomo

White
Blanco

Lacquered aluminium.
Custom RAL colours upon request.
Aluminio lacado.
Colores RAL personalizados bajo petición.

Designs & patterns Diseños y patrones

STANDARD OPTIONS OPCIONES ESTÁNDAR



Coffee
Café

Grey
Gris

Brown
Marrón

GRADIENTS DEGRADADOS



Earth coffee
Earth café

Earth grey
Earth gris

Earth brown
Earth marrón

Customised options Opciones personalizadas

For the structure to meet the requirements of the location, simple drawings like logos or abstract patterns can be reproduced in brilliant or satin colours.

Para que la estructura se adecue a las características del lugar es posible reproducir dibujos simples como logotipos o patrones abstractos en colores brillantes o satinados.



Manufactured with Snina.
Fabricado con Snina.

Measurements Medidas

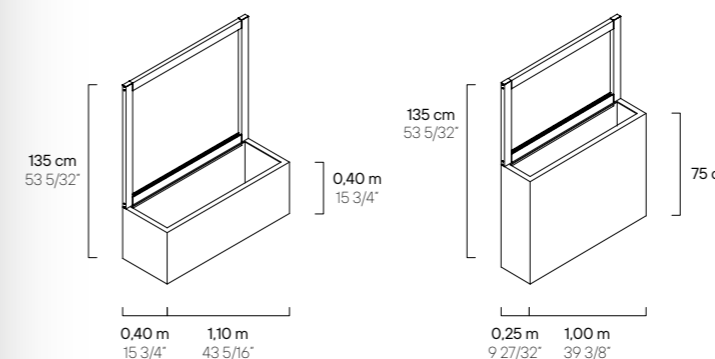

Measurements Medidas	Width Ancho	Height Alto	Depth Fondo
110 x 40	1,10 m 43 5/16"	1,35 m 53 5/32"	0,40 m 15 3/4"
100 x 25	1,00 m 39 3/8"	1,35 m 53 5/32"	0,25 m 9 27/32"

Luis Eslava · Uon Studio · Claire Davies

Collection of designer prints. In addition to drawing inspiration from these proposals, you can customise them to get the result you envision.

The Gradient Collection by Luis Eslava offers gradients with infinite colour and composition possibilities. The Essential Collection by Claire Davies can easily adapt to any environment. Finally, the compositions of the Floral Collection by UON STUDIO include elegant and striking illustrations inspired by textiles.

Patterns Estampados

Luis Eslava · Uon Studio · Claire Davies

Colección de estampados de diseño de autor. Además de inspirarte en las propuestas, puedes personalizarlas para conseguir el resultado que imaginas.

La colección Gradient de Luis Eslava ofrece degradados con infinitas posibilidades de color y de composición. La colección Essential de Claire Davies es fácilmente adaptable a cualquier entorno. Por último, las composiciones de la colección Floral, a cargo de UON STUDIO, incluyen ilustraciones elegantes y vistosas inspiradas en el mundo textil.

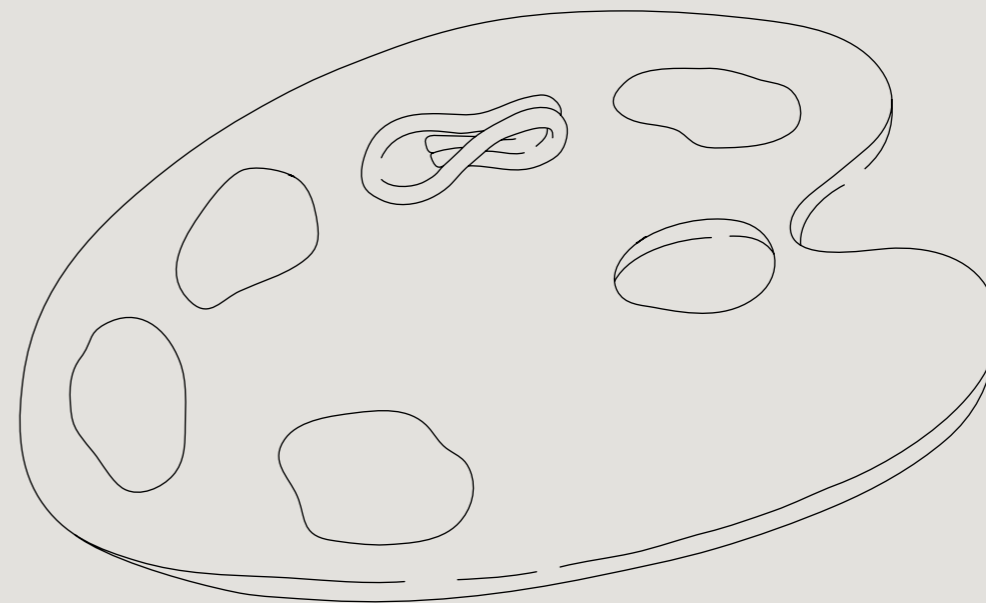

GRADIENT COLLECTION

BY LUIS ESLAVA

Collection comprised of decorative patterns inspired by the transitions that appear between two pure colours, between light and shadows or the grey tones found between black and white. This results in 8 gradient variations that can be adapted to any type of space.

Colección compuesta por patrones decorativos inspirados en las transiciones que aparecen entre dos colores puros, entre las luces y las sombras o los tonos grises que se encuentran entre el blanco y el negro. Como resultado, 8 variantes de degradados adaptables a cualquier tipo de espacio.



CATALOGUE
CATÁLOGO



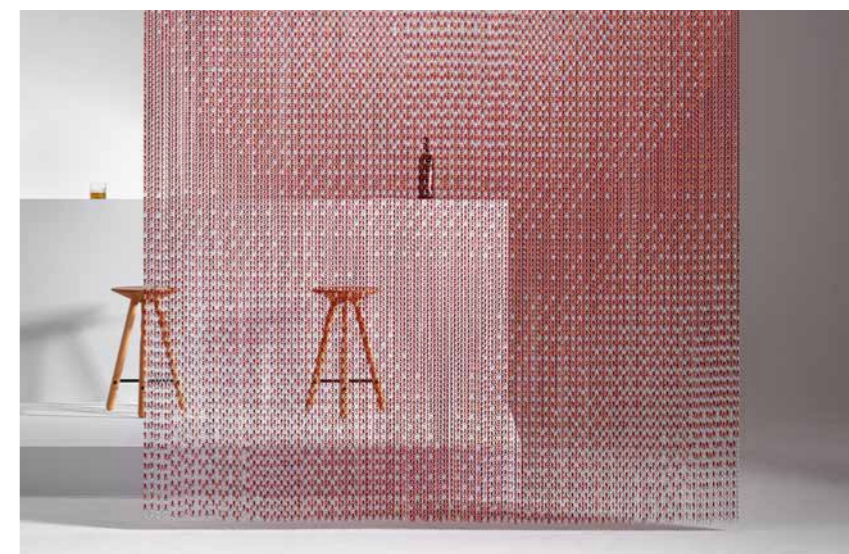
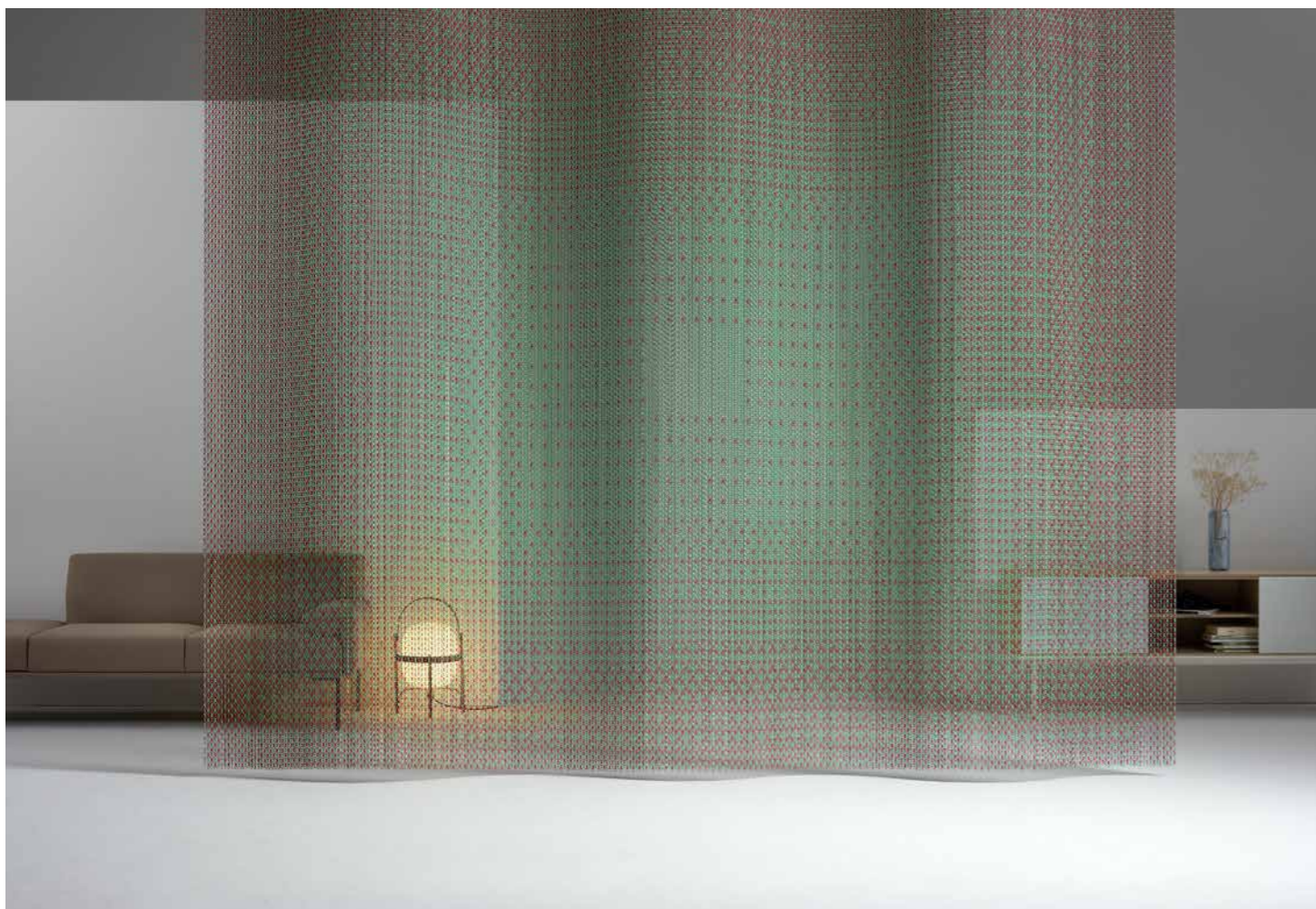



3

Technical features
Aspectos técnicos

ESSENTIAL COLLECTION

BY CLAIRE DAVIES

Versatile patterns for genuine atmospheres. This collection's vast possibilities for customisation in terms of size and colours make it a basic tool for professionals seeking to include a different material, like our aluminium chains.

Patrones versátiles para crear ambientes genuinos. Las grandes posibilidades de personalización en medidas y colores de esta colección la convierten en una herramienta básica para aquellos profesionales que buscan integrar un material diferente como nuestras cadenas de aluminio.



CATALOGUE
CATÁLOGO





3

Technical features
Aspectos técnicos





3

Technical features
Aspectos técnicos



FLORAL COLLECTION

BY UON STUDIO

Discover a new application of prints inspired by UON textile reports.
 Floral prints, tropical gardens, dreamlike kaleidoscopes... The 6 designs by this
 Seville-based studio, all related to nature, bring freshness and personality to any space.
 Descubre una nueva aplicación de estampados inspirados en los reports textiles de la mano de UON.
 Estampados florales, jardines tropicales, caleidoscopios oníricos... Los 6 diseños del estudio sevillano,
 relacionados con la naturaleza, aportarán frescura y personalidad a cualquier espacio.

Tropical Bouquet



3

Technical features
 Aspectos técnicos

Tulips Valley



Bucolic flowers

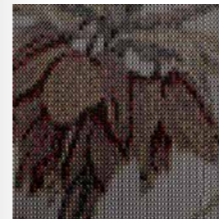

Blooming kaleidoscope



Jungle Birds

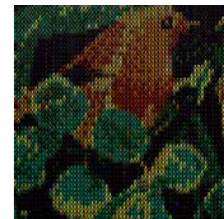
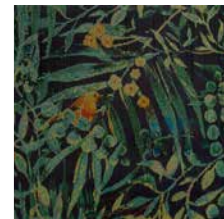

Palm leaves

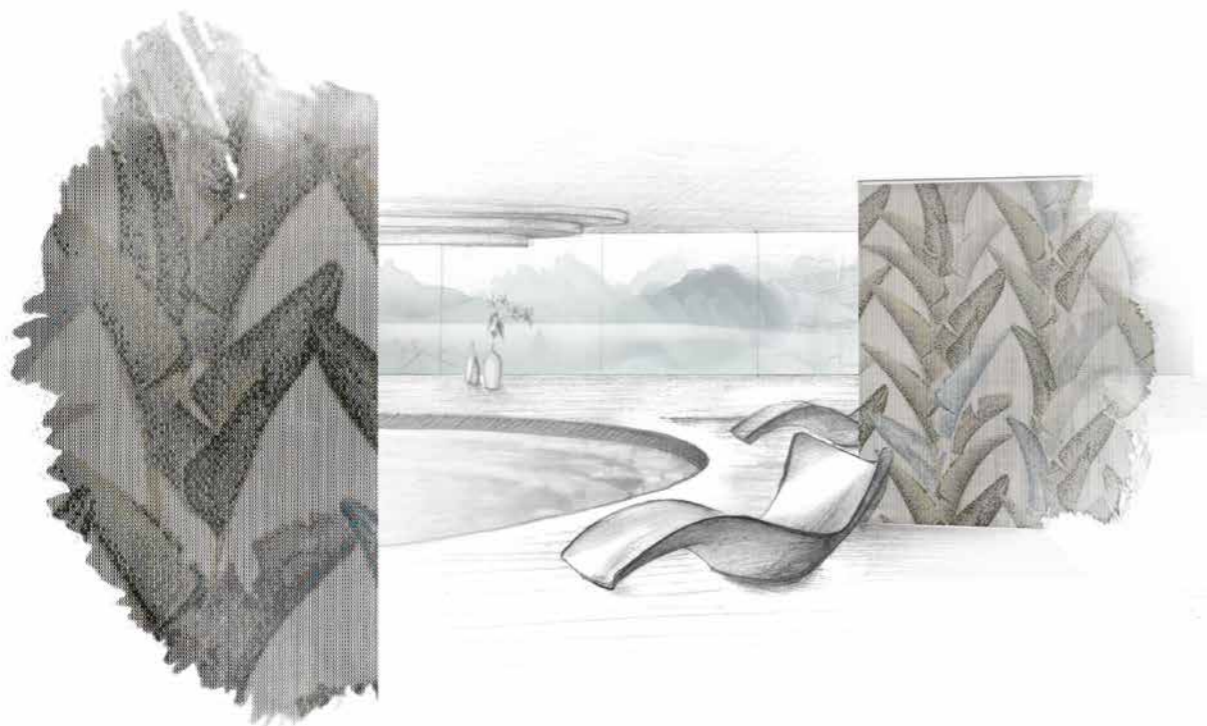

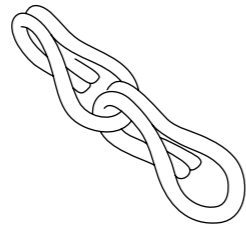

3

Technical features
Aspectos técnicos

The chain links p.134
Los eslabones

Densities p.136
Densidades

Finishes and colours p.138
Acabados y colores

Custom-made p.142
Hecho a medida

Fixing options p.146
Sistemas de fijación

Technical specifications p.154
Especificaciones técnicas

Practical information p.156
Información práctica

Aluminium p.158
El aluminio

Sustainability p.160
Sostenibilidad

Our small chain links, Kriska and Snina,
are the authentic essence of Kriskadecor.

They make large projects a reality.
They have an aluminium soul and dress up in
colours to fit any occasion. They are so similar that
they share all their qualities and possibilities.

The chain links

Los eslabones

La auténtica esencia de Kriskadecor son
nuestras pequeñas piezas que dan vida
a grandes proyectos: Kriska y Snina.

Con alma de aluminio, se visten de colores según lo
requiera cada ocasión. Son muy parecidas, tanto que
comparten todas sus cualidades y posibilidades.

Kriska

The durable and highly versatile star of the show.
La gran protagonista, es resistente y muy versátil.

11,86 mm / 0.467" Width Anchura
23,20 mm / 0.315" Length Longitud
8,00 mm / 0.913" Depth Profundidad



Snina

Snina plays an important role if you are seeking
definition and delicacy.
Snina juega un papel importante cuando se trata
de buscar definición y delicadeza.

8,85 mm / 0.348" Width Anchura
15,7 mm / 0.252" Length Longitud
6,4 mm / 0.618" Depth Profundidad



We work with two different densities.
Depending on the type of project, the chains
can hang symmetrically or asymmetrically.

Densities

Densidades

Trabajamos con dos tipos de densidades.
Dependiendo del tipo de proyecto, las cadenas
pueden colgar de forma homogénea o asimétrica.

Standard

The perfect symmetry. Homogeneously aligned
rows of chains. Suitable for most uses.
La simetría perfecta. Líneas de cadena alineadas
de forma homogénea. Adecuada para la mayoría
de los usos.

Kriska

78 strands per linear metre of rail.
78 tiras por metro lineal de rail.

Snina

100 strands per linear metre of rail.
100 tiras por metro lineal de rail.

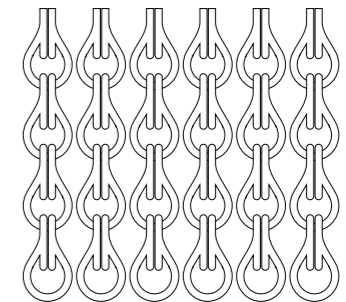

Half-drop

The asymmetrical option. For projects that
require higher opacity.
La opción asimétrica. Para proyectos que
requieren mayor opacidad.

Kriska

100 strands per linear metre of rail.
100 tiras por metro lineal de rail.

Snina

132 strands per linear metre of rail.
132 tiras por metro lineal de rail.

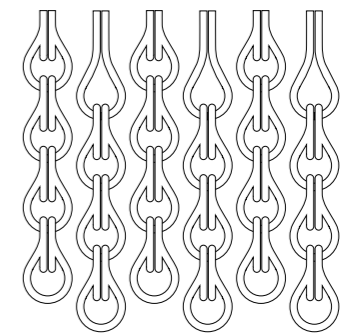

Kriska and Snina are chameleons! They feel at ease and look their best in elegant settings, where the colour black stands out, as well as in fun shop windows, where they attract all eyes. By combining their colours, you can create images and patterns of all kinds. Kriska and Snina are open to all possibilities, so you don't get bored of them.

Finishes and colours

Acabados y colores

Kriska y Snina son muy camaleónicas. Pueden sentirse cómodas y lucir en todo su esplendor tanto en un ambiente elegante, donde destaque el color negro, como en un divertido escaparate donde capten todas las miradas. Combinando sus colores puedes crear imágenes y patrones de todo tipo. Kriska y Snina están abiertas a todas las posibilidades para que no te aburras con ellas.

UPDATED COLOURS
COLORES ACTUALIZADOS



Anodised colours Colores anodizados

The colours of the final product may vary due to lighting effects or the catalogue printing process.
Los colores pueden no ajustarse a la realidad debido a efectos de iluminación o al proceso de impresión del catálogo.

BLACK NEGRO		GREY GRIS		COFFEE CAFÉ	
Brilliant Brillante 20011		Brilliant Brillante 20012		Brilliant Brillante 20021	
Satin Satinado 20211		Satin Satinado 20212		Satin Satinado 20221	
BROWN MARRÓN		SAND ARENA		APRICOT ALBARICOQUE	
Brilliant Brillante 20006		Brilliant Brillante 20028		Brilliant Brillante 20020	
Satin Satinado 20206		Satin Satinado 20228		Satin Satinado 20220	
ORANGE NARANJA		GOLD ORO		LIME LIMA	
Brilliant Brillante 20013		Brilliant Brillante 20003		Brilliant Brillante 20017	
Satin Satinado 20213		Satin Satinado 20203		Satin Satinado 20217	
EMERALD ESMERALDA		MOSS MUSGO		GREEN VERDE	
Brilliant Brillante 20008		Brilliant Brillante 20027		Brilliant Brillante 20004	
Satin Satinado 20208		Satin Satinado 20227		Satin Satinado 20204	
SILVER PLATA		NICKEL NICKEL		AMETHYST AMATISTA	
Brilliant Brillante 20001		Satin Satinado 20214		Brilliant Brillante 20026	
Satin Satinado 20201				Satin Satinado 20226	
PALE PINK ROSA PÁLIDO		PINK ROSA		FLORIDA PINK ROSA FLORIDA	
Brilliant Brillante 20024		Brilliant Brillante 20010		Brilliant Brillante 20016	
Satin Satinado 20224		Satin Satinado 20210		Satin Satinado 20216	
BORDEAUX BURDEOS		RED ROJO		LILAC LILA	
Brilliant Brillante 20018		Brilliant Brillante 20005		Brilliant Brillante 20007	
Satin Satinado 20218		Satin Satinado 20205		Satin Satinado 20207	
BLUE AZUL		COBALT COBALTO		TURQUOISE TURQUESA	
Brilliant Brillante 20002		Brilliant Brillante 20029		Brilliant Brillante 20009	
Satin Satinado 20202		Satin Satinado 20229		Satin Satinado 20209	

Lacquered colours Colores lacados

Outdoor: RAL colours tested under solar radiation. Other RAL colours may be possible upon request.

Interior: Available in all the colours on the RAL colour chart.

Exterior: Colores RAL testados bajo exposición solar. Otros colores RAL se valorarán bajo petición.

Interior: Disponibles todos los colores de la carta RAL.

BEIGE
BEIGE
RAL 1001



BROWN BEIGE
BEIGE PARDO
RAL 1011



LIGHT IVORY
MARFIL CLARO
RAL 1015



GREY BEIGE
BEIGE GRIS
RAL 1019



TRAFFIC YELLOW
AMARILLO TRÁFICO
RAL 1023



PEARL BEIGE
BEIGE PERLADO
RAL 1035



PURPLE RED
ROJO PÚRPURA
RAL 3004



RASPBERRY RED
ROJO FRAMBUESA
RAL 3027



RED LILAC
ROJO LILA
RAL 4001



TRAFFIC PURPLE
PÚRPURA TRÁFICO
RAL 4006



SIGNAL VIOLET
VIOLETA SEÑALES
RAL 4008



SIGNAL BLUE
AZUL SEÑALES
RAL 5005



AZURE BLUE
AZUL AZUR
RAL 5009



PIGEON BLUE
AZUL COLOMBINO
RAL 5014



SKY BLUE
AZUL CELESTE
RAL 5015



CAPRI BLUE
AZUL CAPRI
RAL 5019



WATER BLUE
AZUL AGUA
RAL 5021



PASTEL BLUE
AZUL PASTEL
RAL 5024



LEAF GREEN
VERDE HOJA
RAL 6002



RESEDA GREEN
VERDE RESEDA
RAL 6011



YELLOW GREEN
VERDE AMARILLENTO
RAL 6018



PASTEL GREEN
VERDE BLANQUECINO
RAL 6019



OPAL GREEN
VERDE ÓPALO
RAL 6026



LIGHT GREEN
VERDE LUMINOSO
RAL 6027



The colours of the final product may vary due to lighting effects or the catalogue printing process.

Los colores pueden no ajustarse a la realidad debido a efectos de iluminación o al proceso de impresión del catálogo.

MINT TURQUOISE
TURQUESA MENTA
RAL 6033



OLIVE GREY
GRIS OLIVA
RAL 7002



MOSS GREY
GRIS MUSGO
RAL 7003



BEIGE GREY
GRIS BEIGE
RAL 7006



GREEN GREY
GRIS VERDOSO
RAL 7009



TARPAULIN GREY
GRIS LONA
RAL 7010



BRONW GREY
GRIS PARDUZCO
RAL 7013



UMBRA GREY
GRIS SOMBRA
RAL 7022



PEBBLE GREY
GRIS GUIJARRO
RAL 7032



QUARTZ GREY
GRIS QUARZO
RAL 7039



WINDOW GREY
GRIS VENTANA
RAL 7040



SILK GREY
GRIS SEDA
RAL 7044



PEARL MOUSE GREY
GRIS MUSGO PERLADO
RAL 7048



OLIVE BROWN
PARDO OLIVA
RAL 8008



TERRA BROWN
MARRÓN TIERRA
RAL 8028



GREY WHITE
BLANCO GRISÁCEO
RAL 9002



SIGNAL WHITE
BLANCO SEÑALES
RAL 9003



JET BLACK
NEGRO INTENSO
RAL 9005



WHITE ALUMINIUM
ALUMINIO BLANCO
RAL 9006



PURE WHITE
BLANCO PURO
RAL 9010



GRAPHITE BLACK
NEGRO GRAFITO
RAL 9011



PEARL LIGHT GREY
GRIS CLARO PERLADO
RAL 9022



PEARL DARK GREY
GRIS OSCURO PERLADO
RAL 9023



Each project is unique, so we provide a customised solution for each idea.

Custom-made Hecho a medida

Cada proyecto es único, por eso cada idea obtiene una solución hecha a su medida.

Measurements Medidas

During the project development phase, our clients' specifications are followed rigorously.
Durante el desarrollo del proyecto, se siguen cuidadosamente las especificaciones de nuestros clientes.

SMALL STRUCTURES ESTRUCTURAS PEQUEÑAS



LARGE STRUCTURES ESTRUCTURAS GRANDES



Shapes and volumes

Formas y volúmenes

From simple applications to sculptural pieces. Our chains and fixing options enable us to adapt to all kinds of geometric, organic, or abstract shapes.
 Desde aplicaciones sencillas hasta piezas escultóricas. Nuestras cadenas y sistemas de fijación nos permiten adaptarnos a todo tipo de formas geométricas, orgánicas o abstractas.

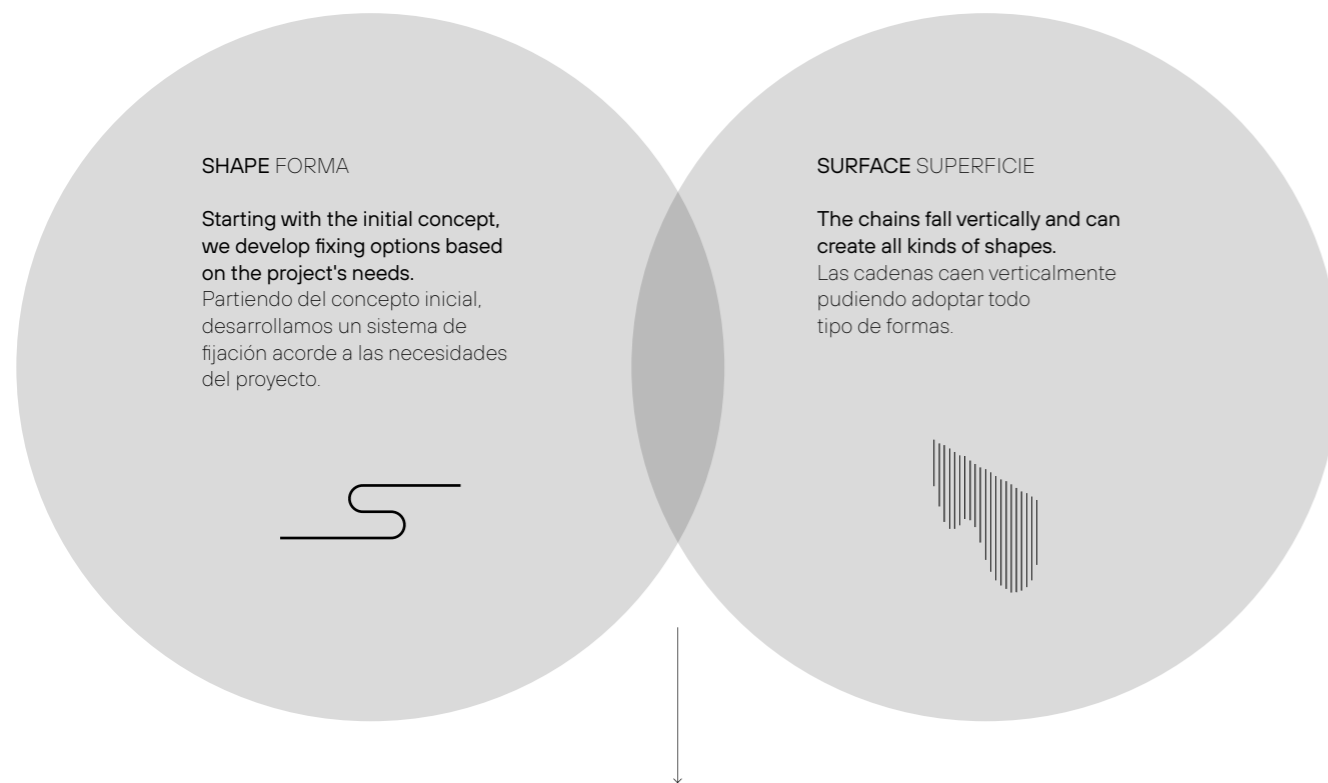

SHAPE FORMA

Starting with the initial concept, we develop fixing options based on the project's needs. Partiendo del concepto inicial, desarrollamos un sistema de fijación acorde a las necesidades del proyecto.

SURFACE SUPERFICIE

The chains fall vertically and can create all kinds of shapes. Las cadenas caen verticalmente pudiendo adoptar todo tipo de formas.

VOLUME VOLUMEN

It allows the combination of different densities, chain lengths and chain shaping, offering a total customisation of spaces. Permite combinar diferentes densidades, longitudes de cadena y vaciados, ofreciendo una total personalización de los espacios.

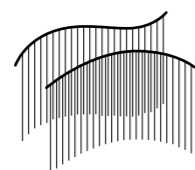

Image reproduction

Reproducción de imágenes

We have developed our own in-house technology to generate images, patterns, or corporate logos, in which each chain link acts as a pixel.
 Hemos desarrollado una tecnología propia con la que podemos generar imágenes, patrones o logotipos corporativos, en los que cada eslabón de la cadena actúa como un píxel.

- 1 Our clients provide us with an image, design, or logo that they want to reproduce. El cliente nos proporciona la imagen, diseño o logotipo que desea reproducir.
- 2 We pixelate it using our own software, and our designers hand-retouch it to 'weave' it as accurately as possible. Lo pixelamos mediante un software propio y nuestros diseñadores lo retocan manualmente para "tejerlo" con la mayor precisión posible.
- 3 We add the profiles needed to leave it installation ready. Incorporamos los perfiles necesarios, dejando el diseño listo para instalar.



Our fixing options combine design and technology to offer an optimal installation solution according to the project's needs.

Fixing options

Sistemas de fijación

Nuestros sistemas de fijación combinan diseño y tecnología, ofreciendo una solución óptima de montaje según las necesidades del proyecto.

FIXING OPTIONS
SISTEMAS DE FIJACIÓN



40x3

BY ROGER VANCELLS

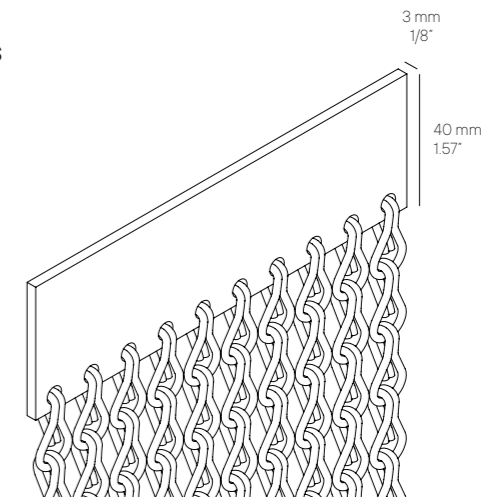

INSTALLATION OPTIONS OPCIONES DE INSTALACIÓN

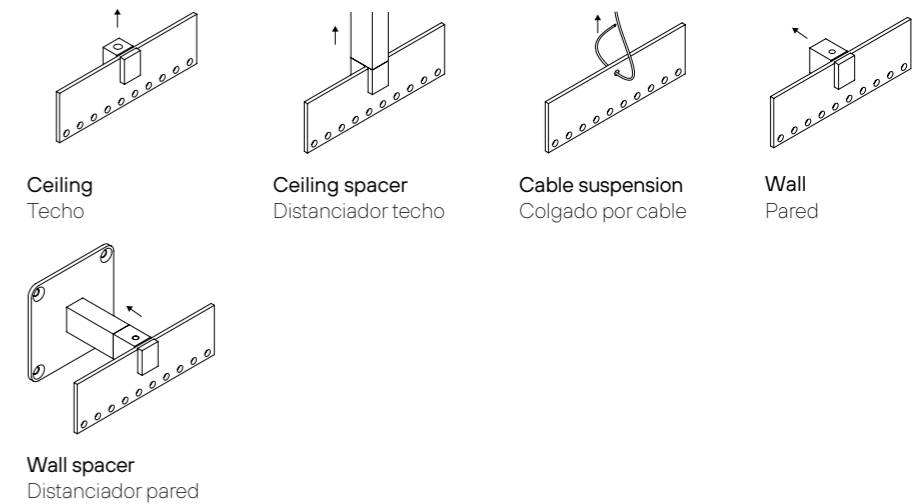

FITTINGS UNIONES

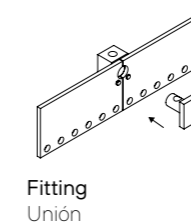

UNDULATION ONDULACIÓN



Light rail suitable for both straight and curved shapes.
Ideal como ligera guía de soporte, adaptable a formas lineales y curvas.

SHAPES FORMAS



SYSTEM SISTEMA

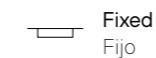

FINISHES ACABADOS

Anodised aluminium / Aluminio anodizado
Custom RAL colour / Color custom RAL

*Cables not supplied.
*No se suministran los cables.

SLIM

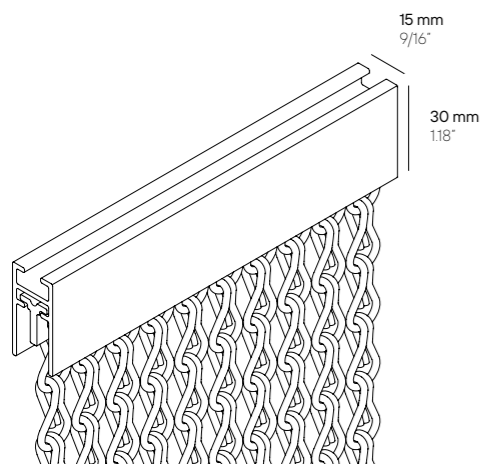

INSTALLATION OPTIONS OPCIONES DE INSTALACIÓN

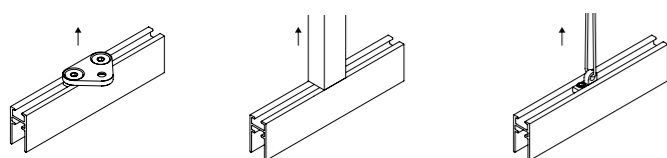

Ceiling Techo
Ceiling spacer Distanciator techo
Cable suspension Colgado por cable

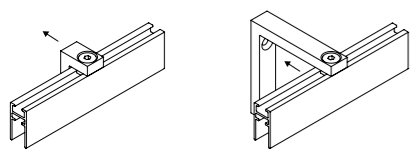

Wall Pared
Wall spacer Distanciator pared

FITTINGS UNIONES

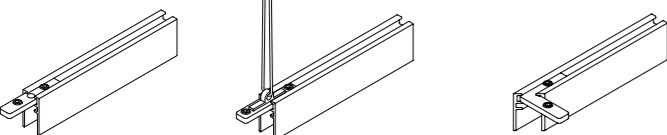

Fitting Unión
Fitting for cable suspension Unión con cable
90° fitting Unión 90°

Rectangular and discreet, this is the ideal solution for projects where the rail doesn't need to stand out.
De forma rectangular y muy sobria, es la solución idónea para proyectos en los que la guía no requiere de ningún protagonismo.

SYSTEM SISTEMA

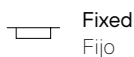

Fixed Fijo

SHAPES FORMAS

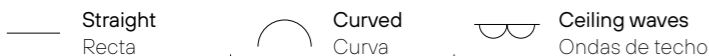

Straight Recta
Curved Curva
Ceiling waves Ondas de techo

FINISHES ACABADOS

Anodised aluminium Aluminio anodizado
Custom RAL colour Color custom RAL

MINIOVAL

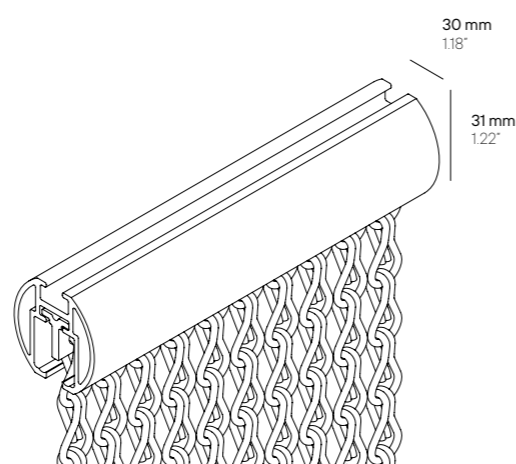

INSTALLATION OPTIONS OPCIONES DE INSTALACIÓN

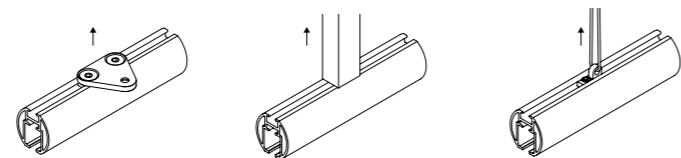

Ceiling Techo
Ceiling spacer Distanciator techo
Cable suspension Colgado por cable

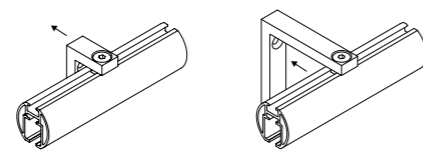

Wall Pared
Wall spacer Distanciator pared

FITTINGS UNIONES

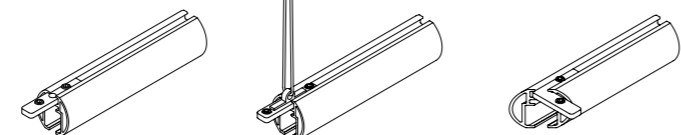

Fitting Unión
Fitting for cable suspension Unión con cable
90° fitting Unión 90°

Tubular rail suitable for both straight and curved shapes.
Perfil de forma tubular que se adapta a líneas rectas o curvas.

SYSTEM SISTEMA

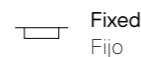

Fixed Fijo

SHAPES FORMAS

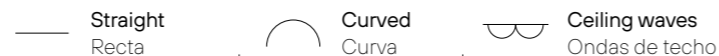

Straight Recta
Curved Curva
Ceiling waves Ondas de techo

FINISHES ACABADOS

Anodised aluminium Aluminio anodizado
Custom RAL colour Color custom RAL

*Cables not supplied.
*No se suministran los cables.

QUAD Traversing

BY ROGER VANCELLS

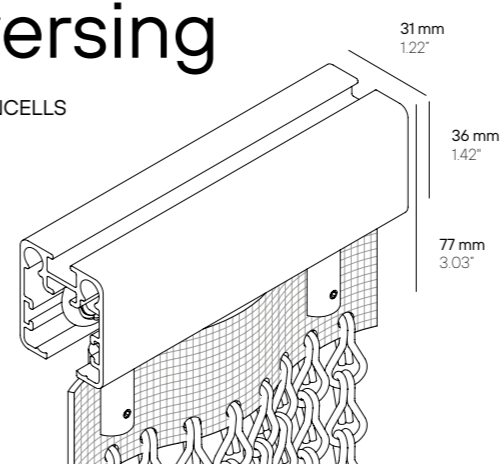

INSTALLATION OPTIONS OPCIONES DE INSTALACIÓN

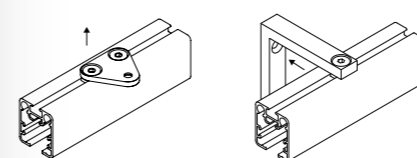

Ceiling Techo
Wall Pared

FITTINGS UNIONES

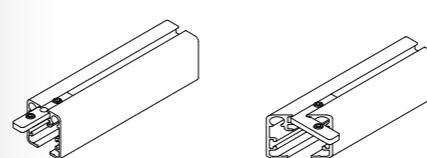

Fitting Unión
90° fitting Unión 90°

UNDULATED ONDULADO



GATHERED FRUNCIDO

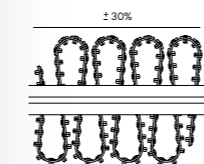

30% gathering over total length
30% de fruncido sobre la longitud total

Profile system that comes with a textile tape to allow the movement of the chains. The tape can create a flat or wavy effect, depending on the project's needs. Adaptable to straight or curved compositions.

Sistema que integra una cinta para dar movilidad a las cadenas. La cinta nos permite crear un efecto plano u onda wave según las necesidades del proyecto. Adaptable a composiciones lineales o curvas.

SYSTEM SISTEMA



Movable Móvil

SHAPES FORMAS

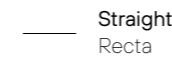

Straight Recta

FINISHES ACABADOS

Anodised aluminium Aluminio anodizado
Custom RAL colour Color custom RAL

QUAD Sliding

BY ROGER VANCELLS

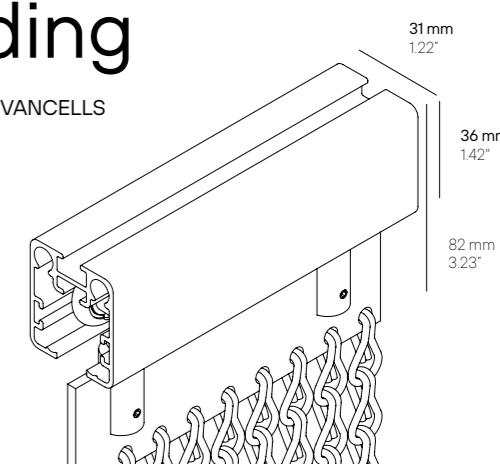

INSTALLATION OPTIONS OPCIONES DE INSTALACIÓN

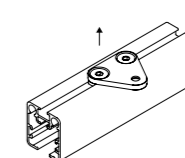

Ceiling Techo

FITTINGS UNIONES

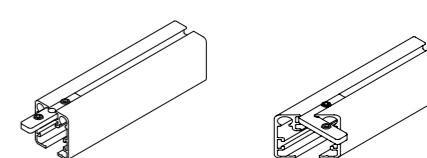

Fitting Unión
90° fitting Unión 90°

Movable profile system with slide rails that allow a 'panel' effect.
Sistema de perfil móvil con guías que permite la creación del efecto "paneles".

SYSTEM SISTEMA

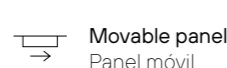

Movable panel Panel móvil

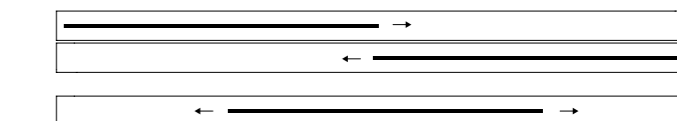

SHAPES FORMAS

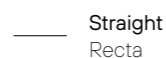

Straight Recta

FINISHES ACABADOS

Anodised aluminium Aluminio anodizado
Custom RAL colour Color custom RAL

BCN TENSED & FRAMED SYSTEM

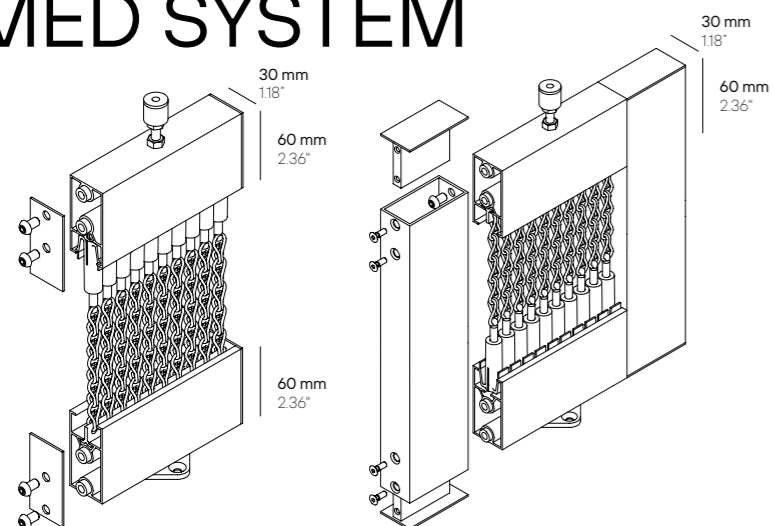

INSTALLATION OPTIONS OPCIONES DE INSTALACIÓN

FRAMED ENMARCADO

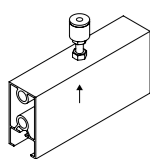

Ceiling and floor
Techo y suelo

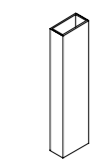
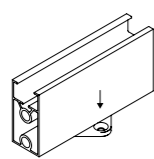

Side profile
Perfil lateral

FITTINGS UNIONES

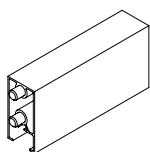

Fitting
Unión

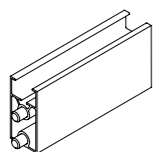

TAUT SYSTEM LENGTHWISE OR FRAMED SISTEMA TENSADO LONGITUDINAL O ENMARCADO

Floor and ceiling fastening profile with a spring system on the upper part to guarantee the stability of the chains.

Perfil de fijación a suelo y techo que incorpora un sistema de muelles en la parte superior para garantizar la estabilidad de las cadenas.

SYSTEM SISTEMA

SHAPES FORMAS

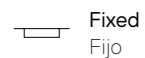

Fixed
Fijo

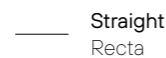

Straight
Recta

FINISHES ACABADOS

Custom RAL colour
Color custom RAL

CLADDING Outdoor

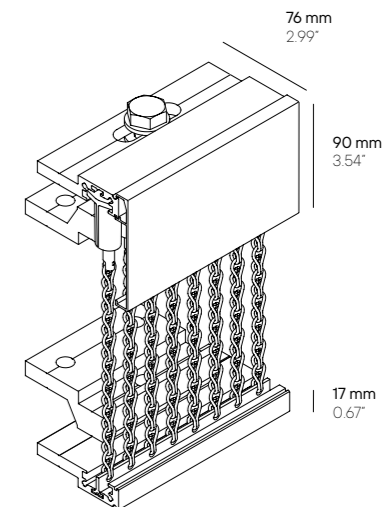

SYSTEM COMPONENTS COMPONENTES DEL SISTEMA

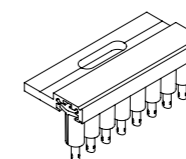

Top fastening
Fijación superior

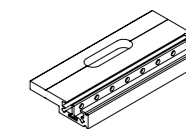

Bottom fastening
Fijación inferior

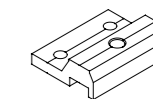

Regulator
Regulador

ACCESSORIES COMPLEMENTOS

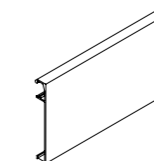

Cover
Embellecedor

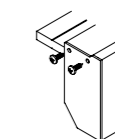

Side lid
Tapa lateral

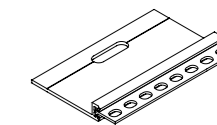

Movement limiter
Limitador de movimiento

BRACKETS ANCLAJES

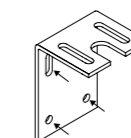

Wall
Pared

The KDC Thin System is specially designed to cover large outdoor surfaces with all the guarantees and maximum quality. Each project is fully customisable in size, shape, and design.

El sistema KDC Thin System está especialmente diseñado para cubrir grandes superficies exteriores con todas las garantías y la máxima calidad. Cada proyecto es totalmente personalizable en tamaño, forma y diseño.

SYSTEM SISTEMA

SHAPES FORMAS

FINISHES ACABADOS

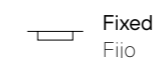

Fixed
Fijo

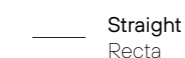

Straight
Recta

Custom RAL colour
Color custom RAL

VOLUME

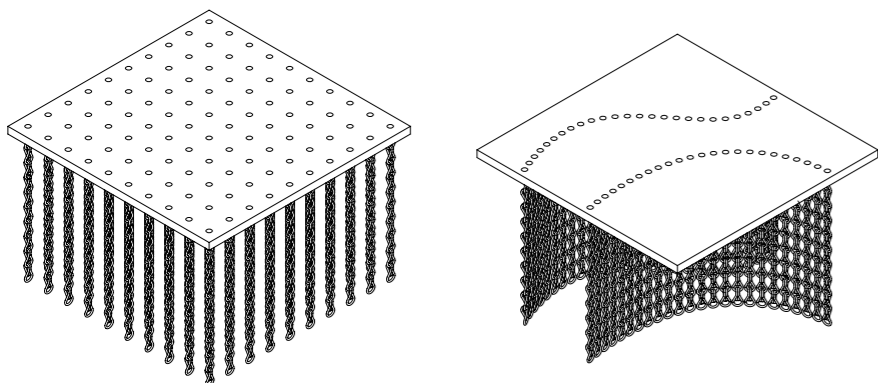

METAL PANEL PANEL METÁLICO

The metal panel for ceilings is a lightweight option that offers many possibilities to customise the space.

El panel metálico para techos es una opción ligera que ofrece múltiples opciones de personalización del espacio.

ACOUSTIC PANEL PANEL ACÚSTICO

Perforated wooden panel that absorbs sound and lowers reverberations, improving the acoustic qualities of any room.

Panel de madera perforada que absorbe el sonido y reduce la reverberación, mejorando la calidad acústica de cualquier tipo de sala.

INSTALLATION OPTIONS OPCIONES DE INSTALACIÓN



Ceiling

Techo

CEILING DECORATION DECORACIÓN DE TECHO

Structure that allows a combination of different densities, shapings and chain lengths. It offers a complete customisation of spaces to achieve surprising effects and volumes with colours and patterns.

Estructura que permite combinar diferentes densidades, vaciados y longitudes de cadena, ofreciendo una total personalización de los espacios para lograr efectos y volúmenes sorprendentes mediante colores y patrones.

SYSTEM SISTEMA

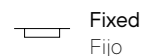

Fixed

Fijo

VOLUMES VOLÚMENES

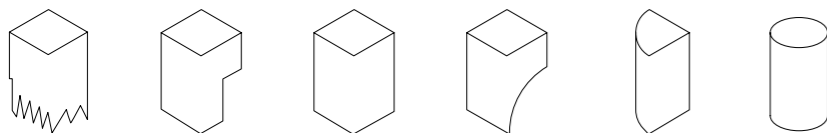

+ Others

+ Otros

FINISHES ACABADOS

Custom RAL colour

Color custom RAL

OTHER OPTIONS OTRAS OPCIONES

In addition to our standard profiles and fixing options, we also offer other solutions that create unique finishes.

Además de nuestros perfiles y sistemas de fijación estándar, ofrecemos otras opciones que permiten conseguir acabados menos habituales.

CHAIN LINKING ANILLADO

The chains can be linked with rings at any height. This option brings rigidity to simulate a fabric and prevents people from going through them.

Las cadenas se pueden enlazar entre sí mediante anillas a cualquier altura. Esta opción aporta rigidez, simulando un tejido y evitando el paso a través de ellas.

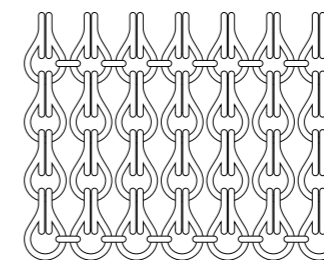

SHAPING VACIADO

Cutting the surface of the chains following straight or curved lines creates surprising effects.

The chain can be framed or left free to move.

El recorte de la superficie de las cadenas siguiendo líneas rectas o curvas permite crear efectos sorprendentes. La cadena puede enmarcarse o quedar libre de movimiento.

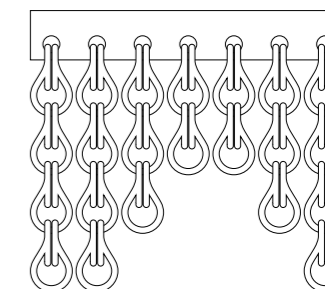

BOTTOM FIXING FIJACIÓN INFERIOR

To prevent the strands from moving, they can be fixed to the floor.

Para evitar que las tiras puedan moverse, es posible fijarlas al suelo.

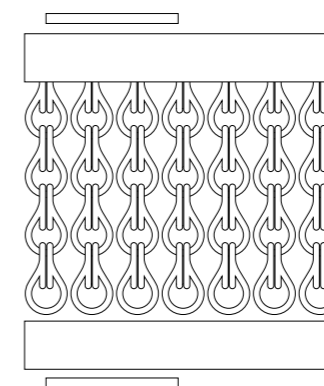

Discover all the technical features of our anodised aluminium chains to ensure a perfect fit with your project.

Technical specifications

Especificaciones técnicas

Descubre todas las características técnicas de las cadenas de aluminio anodizado para una mejor adaptación a tu proyecto.

Thickness

Thickness of the aluminium wire:
Kriska 2 mm / .0787" and Snina 1.5 mm / .0591".

Static load

Maximum static breaking load:
Kriska 17 kg / 37.5 lbs and Snina 11 kg / 24 lbs (approx.).

Material

Anodised aluminium chain with an 8.5 and 12 microns thick coating depending on the colour and finish.

Composition

 Material made of 99.99% aluminium.

Appearance

Soft appearance. Imperceptible roughness.

Opacity

Opacity between 40% and 60% with an angle of inclination of 90°, depending on spacing and finishing (brilliant or satin).

Conductivity

 Does not conduct electricity.

Acoustics

 No sound absorption

Fire-resistance

 A1-rated product (non-combustible).
USA CA Title 19 certificate.

Cleaning

 Resistant to acidic products with pH below 8 (not alkaline products).

Rust

 Rust-resistant.

Temperature

 Recommended working temperature: -30°C / -22° F up to 50°C / +122° F.

Impermeability

 Resistant to sea water.

Weight

 Kriska standard: 3.03 kg / 12 oz. Kriska Half-drop: 3.88 kg / 15 oz.
Snina standard: 2.25 kg / 8 oz. Snina Half-drop: 2.96 kg / 11 oz

Grosor

Grosor del hilo de aluminio:
Kriska 2 mm / .0787" y Snina 1,5 mm / .0591".

Carga estática

Carga estática máxima sin rotura:
Kriska 17 kg / 37.5 lbs y Snina 11 kg / 24 lbs (aprox.).

Material

Cadena de aluminio anodizado con recubrimiento de entre 8,5 y 12 micras, dependiendo del color y acabado.

Composición

 Material compuesto por un 99,99% de aluminio.

Aspecto

Acabado suave. Rugosidad imperceptible.

Opacidad

Opacidad entre 40% y 60% con un ángulo de inclinación de 90°, dependiendo del espaciado y el acabado (brillo o satinado).

Conductividad

 No conduce la electricidad.

Acústica

 No absorbe sonido.

Resistencia al fuego

 Clasificación A1 de resistencia al fuego (no inflamable).
USA CA Title 19 certificate.

Limpieza

 Resistente a productos ácidos de pH inferior a 8 (no a productos alcalinos).

Oxidación

 Resistente a la oxidación.

Temperatura

 Temperatura recomendada de trabajo: -30°C / -22° F hasta 50°C / +122° F.

Impermeabilidad

 Resistente al agua de mar.

Peso

 Kriska estándar: 3.03 kg / 12 oz. Kriska Half-drop: 3.88 kg / 15 oz.
Snina estándar: 2.25 kg / 8 oz. Snina Half-drop: 2.96 kg / 11 oz

Creativity should have the chance to materialise.
Do you need to know how to take measurements
or maintain our chains properly?
Find it out in this section.

Practical information Información práctica

La creatividad debe poder materializarse.
¿Necesitas saber cómo tomar medidas o el
mantenimiento necesario de nuestras cadenas?
Te lo explicamos en este apartado.

Project measurements Medidas del proyecto

- Projects can have any size in terms of both height and width.
- The material is supplied according to the measurements provided by the client.
- They should always include the rail and the fixing system.
- Due to the size of the links and the separation between them, the measurements may not be exact, although they will be close to the height and width requested, without exceeding them, as much as technically possible.
- Los proyectos pueden ser de cualquier dimensión, tanto en altura como en anchura.
- El material se suministra según las medidas indicadas por el cliente.
- Estas siempre incluyen el rail y el sistema de fijación.
- Debido al tamaño de los eslabones y a la separación entre tiras, las medidas pueden no ser exactas, aunque se aproximarán tanto como sea técnicamente posible a la altura y anchura solicitadas, sin sobrepasarlas.

Installation Instalación

- Installation is simple and doesn't require specialised personnel, but you do have to check that the structure where the chains will be installed can bear their weight.
- To achieve the best effect with the chain, we recommend leaving 2 cm (3/4") free at the bottom.
- La instalación es sencilla y no precisa de personal especializado, pero es necesario comprobar que la estructura donde se instalará la cadena resiste su peso.
- Para conseguir un mejor efecto de la cadena, recomendamos dejar libres 2 cm (3/4") en la parte inferior.

Cleaning and maintenance Limpieza y mantenimiento

- Aluminium is a very light and easy to handle material.
- In terms of the cleaning protocol, the chain can be washed and disinfected using two processes to keep its finish intact:
 1. With water and detergent (pH up to 8) and then spraying with an alcohol and water solution (70-30%).
 2. With steam cleaners, if you want to avoid chemical agents.
- El aluminio es un elemento muy ligero y de fácil manipulación.
- En cuanto al protocolo de limpieza, la cadena puede lavarse y desinfectarse mediante dos procesos que respetan su acabado:
 1. Con agua y detergente (pH hasta 8) y posterior rociado con una solución de alcohol y agua (70-30%).
 2. Con limpiadoras al vapor si se quieren evitar agentes químicos.

Kriska and Snina are made of aluminium.
They are lightweight and resistant.

Aluminium

El aluminio

Kriska y Snina están hechas de aluminio.
Son ligeras y resistentes.

Our products are manufactured in our facilities from start to finish: from manufacturing the link chains with aluminium wire to the structures installed in each project. Our chain links are made of 99.99% aluminium and are subject to a special anodised treatment that makes them harder, and grants their colour a higher resistance to climate factors, friction, and rust.

THEY ARE waterproof, odourless, and good light receptors.
THEY ARE NOT magnetic or toxic.

Nuestros productos se fabrican de principio a fin en nuestras instalaciones: desde la elaboración de las cadenas de eslabones a partir de alambre de aluminio, hasta las estructuras que se acaban instalando en cada proyecto. Nuestros eslabones están compuestos por un 99,99% de aluminio y sometidos a un tratamiento de anodizado especial que les proporciona una mayor dureza y resistencia del color a los factores climáticos, así como al rozamiento y a la oxidación.

SON impermeables e inodoros y buenos receptores de la luz.
NO SON magnéticos ni tóxicos.

We develop sustainable solutions to minimise the environmental impact.

Sustainability

Sostenibilidad

Desarrollamos soluciones sostenibles para minimizar el impacto en el medio ambiente.

Our goal at Kriskadecor is to minimise as much as possible our environmental impact, investing resources and effort to that end. Our links are 99.99% aluminium, of which 20% is recycled. Therefore, their production requires fewer resources and reduces our carbon footprint. And best of all, it's a metal with infinite recycling cycles. Aluminium is our main raw material, so we help promote the circular economy thanks to its high recyclability with no quality loss. Moreover, its recycling reduces energy consumption by 95% compared to the bauxite extraction process, the main source of aluminium in the world. Currently, the construction industry recycles between 92% and 98% of aluminium. It's estimated that around 75% of the aluminium recycled in the past 100 years is still in use. In addition, this metal has outstanding properties for both interior design and architecture because it's fireproof, it doesn't rust and it's lighter and more resistant than other materials. As befitting a company committed to caring for the environment, we comply with the 3R rule: reduce, reuse, and recycle. In our production processes, we reuse water, minimising this resource's consumption. Likewise, we contribute to the struggle against climate change, avoiding CO2 emissions and other polluting gases by using 100% green renewable energy.

En Kriskadecor tenemos el objetivo de minimizar al máximo nuestro impacto en el medio ambiente, invirtiendo recursos y esfuerzos en ello. Nuestros eslabones están hechos con un 99,99% de aluminio que, además, incorpora un 20% de material reciclado, por lo que su producción consume menos recursos para reducir nuestra huella de carbono. Y lo mejor, este metal tiene ciclos infinitos de reciclado. Como el aluminio es nuestra principal materia prima, ayudamos a promover la economía circular gracias a su gran capacidad de reciclado sin perder su calidad original. De hecho, su reciclado reduce el consumo energético en un 95% en comparación con el proceso de extracción de la bauxita, principal fuente de aluminio del mundo. Actualmente, en el sector de la construcción se recicla entre un 92% y un 98% de aluminio y se estima que un 75% del aluminio reciclado en los últimos 100 años sigue en uso. Además, este metal tiene unas propiedades inmejorables tanto para el interiorismo como la arquitectura, ya que es ignífugo, no se oxida y es más ligero y resistente que otros materiales. Como empresa comprometida con el cuidado del medio ambiente, cumplimos la ley 3R: reducir, reciclar y reutilizar. De hecho, dentro de nuestros diferentes procesos de producción, se reutiliza el agua para minimizar el uso de este recurso. Asimismo, contribuimos a la lucha contra el cambio climático, evitando las emisiones de CO2 y otros gases contaminantes mediante la utilización de energía renovable 100% verde.

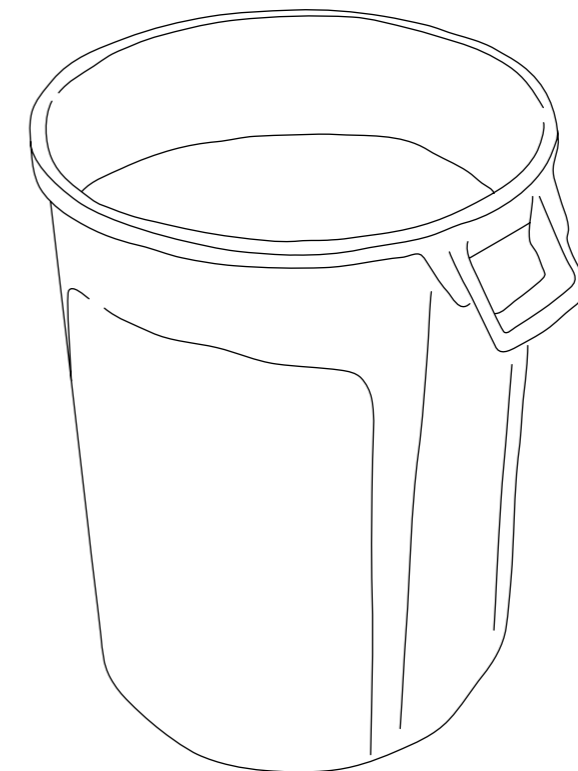



Graphic design and art direction
Diseño gráfico y dirección de arte

Zoo Studio

Photography
Fotografía

Joan Pujol-Creus

Printed in Barcelona
Imprimido en Barcelona

Copyright © Kriskadecor

All rights reserved
Todos los derechos reservados

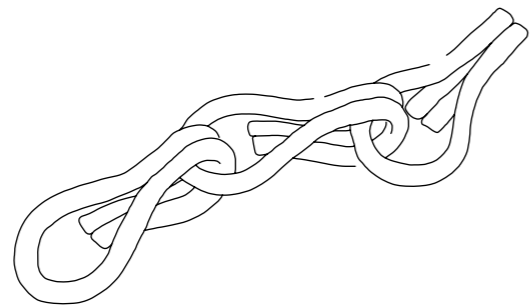

Kriskadecor
Headquarters

Ctra. Rojals, 4
43400 Montblanc
Tarragona, Spain
+34 977 86 00 88
info@kriskadecor.com

-

Kriskadecor
USA

150 SE 2nd Ave
3rd floor, Ste #325
Miami FL 33131
+1 305 438 7944
info@kriskadecor.us

-

kriskadecor.com

The Original · Patent 1932 · Linking Ideas · Since 1926

